

2011



**Affordable Housing Design
Guidelines and Standards**
Family and Senior Apartment Buildings



Region of Peel
Real Property Asset Management
Employee & Business Services
10 Peel Centre Drive, Suite B
Brampton, ON L6T 4B9
Tel: 905-791-7800
e-mail: rpam@regionofpeel.ca
www.peelregion.ca



The compilation of this document is the result of an integrated consultation and collaboration with stakeholders from both the Human Services department and the Real Property Asset Management division.

It is important to acknowledge the core project team, led by Chair Chris Bullock, Manager of Development and Construction and the Project Manager, Veronica Santos, who ensured that the professional expertise within the fields of Construction, Operations and Program/Policy was fully engaged and represented on this team, and further, that alignment with corporate and Council directions and/or authorities were well represented by the content of this document. The core team consisted of the following members: Chris Bullock, Joseph Abraham, Veronica Santos, Bruno Colavecchia, Robb Dods, Olga Tusun-Kalac and Ronald Caldwell.

In addition, the following internal subject matter experts in building components and building systems contributed greatly to the prescriptive specifications that were merged with corporate initiatives such as sustainable, accessible and energy-effective design requirements to produce these standards and guidelines: Chris Bullock, Joseph Abraham, Biljana Bajagic, Steven Belanger, Richard Ngun, Veronica Santos and Daniele Magditsch.

Note: This document is to be read in conjunction with the most current: “The Region of Peel Universal Accessibility Standards for Affordable Residential Properties” and “Crime Prevention Through Environmental Design” (CPTED) and/or any other document referenced in this document.

1.0 General Information

1.1 Background	4
1.2 Introduction	4
1.3 Affordable Housing Design Guidelines and Standards Structure	5
1.4 Process and Products	5
1.5 Regulatory Requirements	6

2.0 Site Selection

2.1 Objective	8
2.2 General.....	8
2.3 Environmental.....	8
2.4 Planning Context.....	9
2.5 Regulatory Approvals	9
2.6 Servicing.....	9
2.7 Access and Transportation	10

3.0 Development

3.1 Objective	12
3.2 Environment	12
3.3 Built Form.....	14

4.0 Technical

4.1 Objective	18
4.2 Structure.....	18
4.3 Foundations Footings.....	18
4.4 Mechanical.....	18
4.5 Plumbing	20
4.6 Electrical.....	22
4.7 Building Envelope	23
4.8 Roof	24
4.9 Windows/Doors/Finish Hardware.....	25
4.10 Keying System	27
4.11 Materials/Finishes	28
4.12 Acoustical.....	29
4.13 Architectural Millwork.....	29
4.14 Equipment/Furnishings.....	30
4.15 Specialties	30

Table of Contents



5.0 Design

5.1 Objective	32
5.2 Safety	32
5.3 Security	32
5.4 Lighting.....	33
5.5 Balconies	33
5.6 Accessibility.....	34
5.7 Outdoor Storage	35
5.8 Entrances/Exits.....	35
5.9 Public Spaces.....	36
5.10 Suite Requirements	44

6.0 Submission Requirements and Format Standards

6.1 Warranties	50
6.2 Drawings	51
6.3 Specifications	52
6.4 Marketing	52

APPENDIX A

Finishes Schedule	54
-------------------------	----

APPENDIX B

Millwork Schedule	58
-------------------------	----

APPENDIX C

Region of Peel Universal Accessibility Standards for Affordable Residential Properties.....	60
--	----

APPENDIX D

Region of Peel Metering Requirements	86
--	----

APPENDIX E

Building Automation Systems Specification	90
---	----

APPENDIX F

Abbreviations, Acknowledgements, Bibliography and References	98
---	----



Table of Contents

1.0 General



1.1 BACKGROUND

The Region of Peel is one of the 49 social housing providers in this Regional municipality. Peel Living, also known as Peel Housing Corporation, is the largest landlord in Peel and one of the largest in the Greater Toronto Area. Peel Region has been building social housing since 1979. Its portfolio includes numerous apartments and townhouses on various sites across the cities of Brampton and Mississauga and the town of Caledon.

The Region of Peel's Council mandate is to provide clean, safe and affordable rental housing and support services to combat homelessness. Its success has been proven time and again as illustrated by Peel Living residents who move from subsidized housing to market rental units or to home ownership.

The Region of Peel is known for its unique approach to building strong communities through mixing tenancies of various income levels, and through its commitment to build sustainable and environmentally friendly developments. It has also received a number of urban design awards. Peel Living has established a strong support system that includes partnerships with community agencies and senior-level governments to assist with their endeavours to stabilize thousands of households in need.

1.2 Introduction

One of the Region of Peel's mandates in building apartment-type buildings (high-rise or low-rise) and/or townhouse developments, is to provide quality housing that is affordable to low- and moderate-income families, seniors and persons with disabilities, as well as, create management programs to ensure that the developments are well maintained and complement their communities.

In order to achieve this goal, the Region has developed this document, which establishes most of its requirements and recommendations. The intent of this document is to guide the developer, consultants and builder in the production of attractive, efficient and functional housing.

The Region is concerned with all aspects of the project, from site selection to design, development, construction, maintenance and management. These guidelines and standards are set up in convenient sections, relative to the project's development process, from schematic design through construction and handover. It covers a broad range of topics from urban design planning issues, the immediate surrounding environment, site, building sustainability and built form to the individual unit requirements.

This document is to be read in conjunction with other guidelines and standards such as the most recent Region of Peel Universal Accessibility Standards for Affordable Residential Properties, as well as, the most recent Crime Prevention Through Environmental Design (CPTED), all municipal, provincial and federal codes, all requirements of Authorities Having Jurisdiction (AHJ) and any other document or report referenced in this manual.

The implementation of the "Ontario Smart Growth Vision" principles is strongly encouraged. Some of the requirements from Leadership in Energy and Environmental Design (LEED) Green Building Rating System in Canada are incorporated in this document pertaining to sustainable sites, water efficiency, energy and atmosphere, materials and resources, and indoor environmental quality. Although it is the Region's intent to have building products consistent with LEED-quality products, it will pursue LEED certification at its discretion. It is our intent to meet the equivalent of a LEED Silver rating through knowledgeable content and material selections. The Region aims to improve occupant well-being by providing quality environmental performance, while also ensuring economic returns on buildings by encouraging the use of established and innovative practices, standards and technologies.

Design and technical issues for both exterior and interior environments are addressed in greater detail in the sections to follow. Issues regarding performance and sustainability are also presented.

Note: This document is to be read in conjunction with the most current: "The Region of Peel Universal Accessibility Standards for Affordable Residential Properties" and "Crime Prevention Through Environmental Design" (CPTED) and/or any other document referenced in this document.

1.3 Affordable Housing Design Guidelines and Standards Structure

The guidelines include both requirements and recommendations to guide the developer, consultants and builder throughout the design and building process. This document defines the nature, functions and elements which combine to form the built environment that the Region aims to create and maintain under the Affordable Housing initiatives. Issues of urban design and built form are of the utmost importance. These guidelines are not intended to curtail them, but rather to enhance the production of attractive, efficient and functional housing.

1.4 Process and Product

1.4.1 Process

- Commitment to finding suitable local solutions that can be implemented effectively and efficiently.
- Facilitate team approach with stakeholders.
- Development and building of housing units on schedule and on budget.
- Consider all aspects of design, development, construction and management while recognizing the social and individual needs of the residents.
- Recognize and understand the diverse preferences and cultural variation within communities.
- Acceptance of good quality proposals only.

1.4.2 Product

- Develop housing projects that are not only affordable, but provide a high-quality of liveable space, amenity, finish and ease of maintenance that meet the current and foreseeable sustainable needs of tenants and the owner.
- Support “Ontario Smart Growth Vision” principles through the development of compact and efficient project(s); and sustainable design philosophy with convenient access to services, such as: education, health care, shopping, public transit and recreation (e.g. parks and recreation centres).
- Provide safe, secure, good-quality affordable rental housing within a healthy and safe environment.
- Provide a universal accessible environment that supports tenants and visitors with disabilities.
- Complement and support the positive characteristics of the context in which the new development is located, and incorporate current and foreseeable needs and requirements of both the residents and the community.
- Provide attractive and innovative housing incorporating efficient space design and energy efficiency measures.
- Incorporate an appropriate mix of different types of units to be built pursuant to the current housing program in effect (consult owner for unit mix requirements).

Note: This document is to be read in conjunction with the most current: “The Region of Peel Universal Accessibility Standards for Affordable Residential Properties” and “Crime Prevention Through Environmental Design” (CPTED) and/or any other document referenced in this document.

1.5 Regulatory Requirements

Provide services, processes, products and workmanship as required by the contemplated project necessary to conform to the current applicable standards, codes and regulations. Consider all of the references and documents such as standards, codes, specifications, forms (e.g. contract, legal, municipal applications), manuals (including installation) and applicable instructions referred to in the documents to be the latest published and/or issued editions at the date of submission of the proposal unless otherwise stated in the document or as required by the AHJ.

The Affordable Housing Design Guidelines and Standards, whether or not referred to in a Request for Proposal (RFP) and/or issued documents for the development of a housing project, shall be established as a minimum acceptable standard of services, materials, products and workmanship. Ensure that materials, products and workmanship meet or exceed requirements of the reference standards specified.

In the event of conflict between documents specified herein, execute the work in accordance with the most stringent requirements.

Where no standards are referred to, provide services, products, materials and workmanship that meet or exceed the minimum requirements of the applicable standards in North America. For reference purposes, applicable standards shall include, but not be limited to: Canadian Standards Association (CSA), National Research Council (NRC), Canadian General Standards Board (CGSB), American Standards for Testing Methods (ASTM), American National Standards Institute (ANSI), Standards Council of Canada (SCC), National Building Code of Canada (NBC), Ontario Building Code (OBC), Canadian Disability Act (CDA), Accessibility Advisory Committee (AAC), American Society of Heating, Refrigeration and Air Conditioning Engineers (ASHRAE), Heating, Refrigeration and Air Conditioning Institute (HRAI), etc.

Note: This document is to be read in conjunction with the most current: “The Region of Peel Universal Accessibility Standards for Affordable Residential Properties” and “Crime Prevention Through Environmental Design” (CPTED) and/or any other document referenced in this document.

2.0 Site Selection



2.1 OBJECTIVE

To select quality sites suitable for the development of affordable housing projects that avoid accruing costs related to site imperfection(s) (including environmental issues) requiring improvements, upgrades and/or remediation efforts.

To promote developments that contribute to the long-term planning vision of the Region of Peel and local municipality and to support and promote the principles of Ontario Smart Growth Vision by selecting sites that can utilize public transit, cycling and walking as alternatives to automobile use.

To determine the scope of required approvals by all Authorities Having Jurisdiction.

To consider the adequacy of existing utilities and municipal services in concert with those proposed to ensure the feasibility of providing a complete package of required services.

To support and promote the principles of Ontario Smart Growth Vision by selecting sites which can support public transit, cycling and walking as alternatives to automobile use.

2.2 General

- The building location on the site shall be carefully considered in the context of any negative impact on the site's environmental and geographic characteristics. Select a suitable building location with a designed footprint that minimizes site disruption.
- The proposed project shall take into consideration the nature of adjacent lands and developments, requiring a careful review of the building(s)' "fit" into the proposed site while restricting the potential negative impact on the existing neighbourhood, roadways and sidewalks, parks and open spaces and properties.
- Incorporation of an emergency power generator and its location within the project shall be carefully evaluated in context with its impact on the surrounding environment. The proponent will produce all the reports, certificates and necessary approvals from the Ministry of the Environment (MOE) in the areas of its location, operations and exhaust, while paying for all associated costs.

2.3 Environmental

- The advantages of any given site will be measured and evaluated against any liability and/or cost that could accrue due to environmental contamination, both past and present.
- A Site Analysis Report(s) shall be provided encompassing: Soil, Geotechnical, Environmental, Sound (Noise Study), Water (Storm Water Management), Existing Structures, Equipment and Services.
- The proponent will be liable for the determination of the site's suitability for development and any costs associated with de-contamination and/or remediation.
- Environmental elements of an obtrusive nature, such as excessive roadway and/or railway noise, foul odours from non-residential uses or excessive airborne pollution shall render such site(s) unacceptable.

Note: This document is to be read in conjunction with the most current: "The Region of Peel Universal Accessibility Standards for Affordable Residential Properties" and "Crime Prevention Through Environmental Design" (CPTED) and/or any other document referenced in this document.

2.4 Planning Context

The proponent shall:

- Develop the site to conform to the Municipal Official Plan and Zoning By-laws.
- Provide a detailed planning analysis that describes the urban design objectives of the project and highlights the degree of their compatibility with the Official Plan.
- Re-zone the site for the intended use. Resolve any outstanding issues in regards to Zoning By-law Amendments.
- Obtain all necessary clearances regarding easements and/or consent to sever for the proposed project's site.
- Identify existing uses in the areas surrounding the proposed development's site and assess the appropriateness and/or limitations that they might impose on the proposed project and vice versa.
- Obtain all necessary clearances and written approvals from the Heritage and Historical Society (HHC). Assess the impact that the existing structure(s) will impose on the proposed project.

2.5 Regulatory Approvals

The proponent shall:

- Identify and provide a comprehensive list of all anticipated approvals required for the development of the project.
- Obtain approvals and/or permits, which could involve all three levels of government (federal, provincial and municipal) as well as various utilities providers.
- Secure all required planning and/or development approvals, demolition and/or building permit(s), utility agreements and charges. Approvals by Provincial Ministries such as the MTO and MOE shall be in place prior to the start of construction.
- Assume any and all costs associated with securing approvals.
- Obtain clearance and approval from the Regional Conservation Authority (TRCA, CVCA) for the development of the proposed project. The latest Regional flood plain mapping should be reviewed to ensure the viability of this proposal.

2.6 Servicing

The proponent shall:

- Review the adequacy and availability of municipal services and utilities.
- Pay for all costs associated with any upgrades and/or relocation of existing on-site or off-site services by the proposed development (including connections to Municipal lines off site).
- Supply and pay for all future services that do not exist, but which are required to support the project.
- Provide all required supplementary equipment and services, such as: gas, water and hydro meters, cable, telephone and other service appurtenances that are to be co-ordinated and integrated into the project.
- Provide facilities for loading and unloading, refuse collection, recycling and snow removal. The design standards of the Region of Peel and Municipal requirements shall be met as required.
- Ensure the design standards of the Region apply where private contracting for the above listed services is permitted or required.
- Seek approvals from the Region of Peel for any contemplated septic system. It is the preference of the Region of Peel to have all projects on formal Municipal services.

Note: This document is to be read in conjunction with the most current: "The Region of Peel Universal Accessibility Standards for Affordable Residential Properties" and "Crime Prevention Through Environmental Design" (CPTED) and/or any other document referenced in this document.

2.6 Servicing cont'd

- Manage and integrate services into the project by means of concealment/camouflaging/or screening.
- Make provisions for installation of any required duct banks from the nearest point on the street to the building and for fibre optic cable termination in the Superintendents' office and electrical or Information Technology (IT) rooms.
- Provide a minimum 50 mm (2 in.) diameter distribution conduit for a fibre optic cable or as specified by the Region of Peel IT division.
- Provide structural support for equipment as per Regional IT guidelines.
- Carry a cash allowance for fibre optic cable installation that is to be expended as approved by the owner.

2.7 Access and Transportation

- Urban sites close to various means of public transit and other amenities are preferred to suburban sites.
- The proposed development shall be situated close to existing and proposed public transit routes, pedestrian trails, bikeways and bicycle laneways.
- An internal road network shall be designed to enable vehicular traffic to enter and exit the site while travelling in a continuous forward direction.
 - This feature shall extend to the entry/exit points at the main roadway and also to the drop-off and parking area(s), where possible.
- The proponent shall provide a detailed traffic signage and parking demarcation plan to be approved by the owner.
- The road network and flow of traffic shall be designed to complement the development, avoiding the glare of car headlights into the windows of ground and/or first floor units.
- Accessibility requirements noted in Appendix C shall apply.
- Accessibility Advisory Committee (AAC) approval for Municipal site plan approval process is required.

Note: This document is to be read in conjunction with the most current: "The Region of Peel Universal Accessibility Standards for Affordable Residential Properties" and "Crime Prevention Through Environmental Design" (CPTED) and/or any other document referenced in this document.

3.0 Development

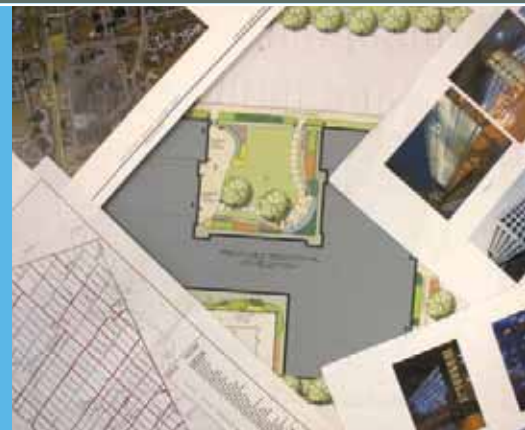

3.1 OBJECTIVE

To provide sustainable housing that is consistent with the demands of the affordable housing provider's program and funding criteria and that can be delivered in a predictable and timely fashion. The development project shall incorporate current Region energy conservation, environmental integration, waste management and recycling, universal accessibility and sound urban design practices.

Through the use of various materials, design features and colours, the "development" shall provide a visually appealing aesthetic that "fits" within the context of the site, neighbourhood and surrounding community while providing all the required functionality as described in this document.

To create patterns of built form, densities and use distribution that are consistent with, but not limited to, the principles of Ontario Smart Growth Vision.

3.2 Environment

The proponent shall:

- Assess/audit building performance and compliance with the latest energy codes and requirements (CBIP, NRC, MEC, ASHRAE 91-2001, etc.).
- Ensure that the overall performance of the new development exceeds minimum regulatory requirements without unwarranted constraint on other areas.
- Evaluate and review the proposed building envelope design with the owner for approval.
- Submit proposed distribution systems of the following: systems and equipment for auxiliaries, heating ventilation and air conditioning system, service water heating, lighting and energy management.
- Balance effective industry practices and emerging design and construction concepts that have been proven effective.
- Construct a project checklist from the latest LEED Canada New Construction (NC) Rating System for low- or high-rise residential buildings.

3.2.1 Recycled & Sustainable Products

- Build to the equivalent of a LEED Silver rating and quality level.
- Reuse to the extent possible, existing materials situated on the site.
- Use to the extent practical, "low embodied energy" products.
- Use products that contain recycled material.
- Use products with projected high-performance standards, long life-cycles, high efficiencies and potential for recycling.
- Consider rapidly renewable materials and products for 5 percent of the total value of all building materials and products used in the project.
- Favour locally produced materials in order to support Regional economic growth.

Note: This document is to be read in conjunction with the most current: "The Region of Peel Universal Accessibility Standards for Affordable Residential Properties" and "Crime Prevention Through Environmental Design" (CPTED) and/or any other document referenced in this document.

3.2.2 Waste Reduction

- Consider the implementation of grey water recycling systems, such as rainwater collected for irrigation or toilet use.
- Provide space in each kitchen to manage recycling.
- Impose a program to reduce waste from construction and demolition (if applicable) activities.
- Develop and implement a waste management plan, quantifying material diversion goals for construction materials used both on and off site.
- Implement and conform to the CCA-81 “A Best Practices Guide to Solid Waste Reduction” in accordance with the federal, provincial and Municipal waste guidelines.
- Where possible, recycle and/or salvage construction, demolition and land clearing waste.
- Designate a specific area for the collection of construction recyclables on site.
- Design the proposed project to incorporate building materials efficiently to minimize waste.

3.2.3 Health and Safety

- Use low emissivity construction adhesives, sealants and finishes (paints, carpet, composite wood, etc.).
- Adhere to zero use of volatile organic compounds (VOCs), carbon-containing gases and vapours, or formaldehyde.
- Not use products containing asbestos, lead and other potentially harmful materials.
- Provide storage rooms that are ventilated to the exterior.
- Use easy cleaning flooring materials that do not absorb contaminants.
- Comply with MOL laws and policies including OHSA, WSIB and HSA.
- Identify all confined spaces existing within the proposed design.
- Complete and post “Form 1000” from the MOL in the construction office.
- Provide a window washing system (roof anchors, etc.), as per OBC requirements.
- Provide fall protection as per Regional requirements.
- Provide and implement pest control measures during demolition of the existing structures and for the duration of the project, as per industry standards and Health Canada guidelines.
- Design the project to implement features that will contribute to pest control for the duration of the project.
- Ensure electrical distribution panels have detailed ARC flash hazard labels placed on them as identified in CSA Workplace Electrical Safety Standard Z462-08, annex Q4.
- Ensure all roof access points are located at a minimum distance of 1,800 mm (6 ft.) away from the edge of the building (refer to Section 4.8).
- Ensure any equipment located on the rooftop is located at a minimum of 1,800 mm (6 ft.) away from the edge of the roof. If this is not possible, appropriate guardrails must be installed on the edge of the roof to provide an appropriate fall protection barrier as per OHSA requirements (refer to Section 4.8).

Note: This document is to be read in conjunction with the most current: “The Region of Peel Universal Accessibility Standards for Affordable Residential Properties” and “Crime Prevention Through Environmental Design” (CPTED) and/or any other document referenced in this document.

3.2.4 Environmental Protection

- Conserve existing natural areas by restoring any damaged areas and incorporate new areas to provide habitat and promote biodiversity.
- Incorporate landscaping elements to provide maximum shade for hard surface areas.
- Preserve significant and healthy trees.
- Relocate or replace (if necessary) existing significant/healthy trees with new trees of same or similar scale and species, where design requires.
- Provide raised garden plots for residents' use if space permits in seniors' buildings.

3.3 Built Form

The proponent shall:

- Design landscaping plans that promote the planting of hardy, water saving, indigenous species, especially in passive areas, to reduce the demand for irrigation and maintenance.
- Design building(s) in compliance with all applicable codes, regulations and Municipal by-laws, including but not limited to the OBC, OFC and MNECB.
- Emphasize the development's physical presence (scale) and its visual relationship to the surrounding built environment.
- Create a building with a unique expressive identity and distinctive presence that will project to the neighbourhood.
- Highlight and capture views that emphasize the important characteristics of a neighbourhood (street façade, urban park, urban square, village green, boulevard, laneway, etc.) that can create a strong sense of community.
- Design and orient the building to take into consideration climatic factors where there are maximum benefits to be derived from natural lighting, energy efficiency (e.g. solar heat gain) and protection from weather elements.
- Design the ground floor of the building to express the individuality of the residential/commercial units through architectural expression and the inclusion of entrance doors and windows addressing the street, where applicable.
- Refrain from superfluous and fallible design gestures and fads.
- Strive to achieve superior performance standards of the development through an elegant, simple and effective design and detailing.
- Design the building to take into consideration the potential negative impacts of adjacent properties including, but not limited to, overshadowing, overlooking and wind-tunnel effects. Therefore, the building's height and mass shall be appropriate to the type and nature of adjoining development.
- Design the building and/or dwelling units (ground-related residential units) to have an identifiable and distinguishable design delineation of "front" and "back," and "public" and "private."
- Locate mechanical equipment, elevator or telecommunications rooms above the roof level and integrate them with the architectural treatment of roofs and screen them from view.
- Design the exterior space of the proposed project to comply with CPTED principles (refer to References section).

Note: This document is to be read in conjunction with the most current: "The Region of Peel Universal Accessibility Standards for Affordable Residential Properties" and "Crime Prevention Through Environmental Design" (CPTED) and/or any other document referenced in this document.

3.3.1 Exterior Space

- Design exterior spaces to be defined as “outdoor rooms.” Utilize the existing site’s features in creating compatible and well-defined amenity areas for adults and/or child-oriented activities.
- Design private spaces and ground-related dwelling units to be clearly identifiable as territorial space.
- Design the exterior yard as an extension of the indoor (apartment) environment to be used for recreational purposes.
- Avoid creating residual, unusable spaces.
- Create well-defined public places (street, garden, park, walkway, mews, square, etc.) through the massing of built-form.
- Provide and define the design intent of the exterior spaces with regard to layout, purpose, size, quality, sequence and design features.
- In family apartment buildings, consider the following:
 - Design spaces for appropriate uses, for both active and passive activities, such as for toddlers, pre-teens, teenagers and adults.
 - Design tot lots to be in close proximity of the dwelling unit(s) to allow monitoring of young children by parents and adults.
 - Provide essential recreational area(s), such as a playground, a tot lot and hard play surfaces.
 - Design and install all playground equipment in compliance with the CAN/CSA-Z614 Children’s Play-Spaces and Equipment standards.
 - Locate pre-school play area within walking distance from the building’s residential units (dwellings, windows) and/or communal spaces. They shall be located adjacent to communal laundry room, with good sightlines to play area.
- Minimize overshadowing of amenity spaces (including recreational) by buildings. Shading to be created through natural means (e.g. deciduous tree planting).
- Design dwelling units at ground, with direct access from the street, to have enhanced privacy through the creation of a buffer zone(s). Provide separation spaces by incorporating private outdoor amenity space, landscaping and shifting grades.

3.3.2 Landscaping

- Design landscaping to complement the development and amenity spaces, enhance the image of the neighbourhood and address practical considerations, such as wind protection, buffering and shade.
- Conduct a site audit and assess all the existing landscape and topographical features of the site in terms of their potential merit to the development.
- Develop a site plan that utilizes and complements existing landscaping features and topography. Maintain part of the site in its natural state where practical and appropriate.
- Evaluate topographic features such as hills and valleys and regard them as an asset to the development.
- Identify any of the site’s shortcomings with regard to pedestrian use and the location of amenities.
- Ensure that all necessary precautions are in place to protect existing landscaping from damage during construction.
- Consider reducing the building footprint to exceed local zoning’s open space requirements.

Note: This document is to be read in conjunction with the most current: “The Region of Peel Universal Accessibility Standards for Affordable Residential Properties” and “Crime Prevention Through Environmental Design” (CPTED) and/or any other document referenced in this document.

3.3.2 Landscaping cont'd

- Plan and design landscape elements to create a planted environment suited to the development.
- Use landscaping for practical benefits and solutions, such as:
 - A colonnade of trees for protection from sun, rain and wind.
 - A grid of trees that will produce a “roof canopy” of foliage to create a secluded sitting area for passive recreation.
 - A berm adjacent to an open sodded area, which will act as a separation between outdoor spaces and can also be used for an informal sitting.
 - The planting of trees and shrubs to define pedestrian traffic patterns at sidewalks.
- Ensure all outdoor furniture and amenity elements are durable and low maintenance.
- Design outdoor site areas and furniture offering comfort and shelter.
- Provide shaded sitting areas with benches and trees.
- Ensure that outdoor furniture design complements the landscape and building design while being ergonomic.
- Ensure outdoor furniture design on the site is unified in style (e.g. garbage receptacles, benches, etc.).
- Provide garbage receptacles at each amenity area.
- Design site landscaping layout to accommodate and support all desired and required outdoor activities. This is site specific and should be discussed with Region of Peel staff.
- Consider the ease of maintenance of grounds (hard and soft surfaces) and snow removal. For areas that are to be designated for snow storage, consider snow drifting patterns, and consider the use of planting and screening to mitigate drifting.
- Design landscape layout to support a motorized equipment maintenance program.
- Avoid small sodded areas and oddly shaped corners.
- Provide sufficiently wide mowing strips between lawns, planting beds, buildings, retaining walls, planters or steps in order to avoid the need for trimming the edge of grass areas.
- Make provisions for a future high-efficiency irrigation system supplied by a storm water cistern.

3.3.3 Storm Water

- Ensure the management of rain and snowmelt respects the site’s existing watershed and complies with CVCA, TRCA and Municipal storm water regulations.
- Provide innovative design options which might incorporate detention ponds, emergency spillways and/or wetlands. Co-ordinate design with the Regional watershed requirements.
- Limit the extent of impervious surfaces.
- Limit the amount of storm water runoff by encouraging on-site infiltration and by designing swales and permeable surfaces.
- Reuse storm water for irrigation and toilet flushing where possible.
- Employ natural treatment systems to improve storm water quality before it exits the site.

Note: This document is to be read in conjunction with the most current: “The Region of Peel Universal Accessibility Standards for Affordable Residential Properties” and “Crime Prevention Through Environmental Design” (CPTED) and/or any other document referenced in this document.

3.3.3 Storm Water cont'd

- Review and comply with the current MOE Storm Water Management Practices Planning and Design Manual.
- Create water retention (holding) ponds to manage storm water influxes.

3.3.4 Signage

- Provide a comprehensive signage proposal that takes into consideration the physical layout of the project through a sense of orientation, location, direction and distance.
- Provide an address and units numbering system that conveys clear and detailed identification.
- Provide text and identification plates for all multi-purpose and utility rooms.
- Affix unit numbering system to the suite entry door using tamper-proof membrane screws (refer to Section 4.9.3).
- Submit all of the proposed signage (both exterior and interior) to the Region for review and approval prior to seeking Municipal approvals and/or installation.
- Provide project identification sign(s) at the main entrance that illustrate the project's marketing logo, the name and address of the building and that are presented in a formal setting that provides a design feature for the project that is easily visible from the street in all approaching directions. Submit to the Region of Peel for review and approval.
- Obtain all necessary permits and co-ordinate installation of signage.
- Ensure signage is of good-quality, durable, low maintenance and vandal resistant.
- Site identification and/or directional signs such as project identification, maps and layouts must be weather-resistant and illuminated for visibility at night – use external, direct light source.
- Ensure that the project identification sign(s) complements the building(s) design and the exterior materials used.
- Provide internal way-finding signage in all lobby areas and at each elevator location.
- Ensure vehicular directional signage is painted on the road surface and/or indicated on identification signs (e.g. one-way notifications, stop signs, yields and flow requirements).

3.3.5 Circulation

- Design vehicular and pedestrian entrances to evoke a sense of arrival (e.g. drop-off, canopy, change of hard surface material from concrete to interlock and/or stone).
- Orient the main entrance to the building directly to the street to allow accessibility from public sidewalks.
- Provide a canopy, extending towards the street, that will provide weather protection at the main entrance to the building (refer to Section 5.8.1).
- Provide wide multi-purpose pathways for different users (e.g. children on bicycles, pedestrians and barrier-free accessibility).
- Design the layout of walkways to follow natural pedestrian traffic patterns to discourage routing across lawns and play areas.
- Design walkways to be a hard surface such as concrete, unit pavers, natural stone pavers or other suitable material.
- Use landscape elements such as trees and shrubs to define circulation edges, which will also be a benefit for microclimatic conditions.
- Design all circulation areas to accommodate barrier-free usage and have an appreciation for universal accessibility.

Note: This document is to be read in conjunction with the most current: "The Region of Peel Universal Accessibility Standards for Affordable Residential Properties" and "Crime Prevention Through Environmental Design" (CPTED) and/or any other document referenced in this document.

4.0 Technical



4.1 OBJECTIVE

To design an effective and durable building envelope (cladding systems) that achieves optimal energy efficiency (limits energy use) and maintains a comfortable interior environment.

4.2 Structure

The proponent shall:

- Design reinforced cast-in-place concrete structure.
- Design and construct adjoining dwelling units, party walls and utility rooms with appropriate sound transmission ratings:
 - Impact Insulation Class (IIC) rating as per OBC requirements.
 - Sound Transmission Class (STC) rating as per Section 4.12.
- Use hot dipped galvanized steel ties for anchorage to substructure in masonry veneer construction.
- Protect the concrete from weather elements during setting time.
- Ensure the roof load calculations consider future installation of photovoltaic system.

4.3 Foundations/Footings

The proponent shall:

- Insulate and waterproof foundation walls where there are basements and/or underground garages.
- Install waterproofing membrane equivalent to MiraDRAIN® along with adjacent drainage system.
- Maintain continuity of air barrier, vapour barrier and insulation from foundation to structure.

4.4 Mechanical

The proponent shall:

- Design mechanical systems in compliance to ASHRAE and HRAI standards.
- Specify and install mechanical equipment that is energy efficient and meets ENERGY STAR designation.
- Not combine mechanical room with any other service room(s). Locate mechanical room(s) in one area, adjacent to other service rooms, and preferably accessible by a service corridor. Locate as far away as possible from residential dwelling units.
- Select materials and equipment from major reputable manufacturers with the ability to provide competent and thorough technical services through local representatives and with the ability to expeditiously deliver spare parts.
- Provide high-output exhaust air exchange to prevent mould and mildew growth within the units.
- Ensure all equipment is properly identified and tagged. Affix nameplates to remote control equipment (e.g. starters, switches) indicating equipment function and systems served.
- Specify energy efficient HVAC equipment that is in compliance with ASHRAE 90.1 Standard efficiency levels.
- Ensure building(s) are air conditioned throughout.

Note: This document is to be read in conjunction with the most current: “The Region of Peel Universal Accessibility Standards for Affordable Residential Properties” and “Crime Prevention Through Environmental Design” (CPTED) and/or any other document referenced in this document.

4.4 Mechanical cont'd

- Ensure all equipment reference numbers are provided in a catalogued submission at building handover.
- Ensure air conditioning equipment does not use fully halogenated Chlorofluorocarbons (CFCs). Only energy efficient equipment that meets or exceeds Natural Resources Canada Energy Efficient Ratio (EER) shall be used.
- Ensure equipment carries a performance energy verification certificate issued by an organization that is accredited by the Standards Council of Canada (SCC).
- Ensure storage room(s) are ventilated and exhausted directly to the exterior. Exhaust fans' air quantities (litres/second) are to comply with the applicable codes and ASHRAE standards.

4.4.1 HVAC

- Provide hydronic-type heating, roof mounted make-up air systems.
- Provide anodized or powder-coated aluminum watertight louvers with insect screens at all fresh intake openings.
- Provide and co-ordinate access panels.
- Provide hydronic-type heating system(s) combined with fan coil units complete with HRVs. Four pipe fan coil system is preferred.
- Design system using gas-fired chillers/heaters with double-effect (two-stage) absorption.
- Provide Building Automation System (BAS) to optimize the start-up (scheduling) and performance (adjustment, monitoring and reporting) of HVAC equipment and alarm systems utilizing computerized Direct Digital Control (DDC). Co-ordination with other IT requirements must be considered (refer to Appendix E).
- Provide rooftop mechanical systems installations to facilitate re-roofing in the future.
- Insulate all heating and cooling systems supply and return lines that pass through unconditioned space.

4.4.2 Exhaust Fans

- Provide direct drive-type fans, mounted in a wall duct, complete with louvers and automatic shutters. Louvers to be of anodized or powder-coated aluminum construction and flush mounted to the outside wall.
- Provide bathroom exhaust fans that are ceiling-mounted, energy-efficient, high-volume, quiet and connected to the light switch or wired directly to the HRV controllers.
- Provide 100 L/s (200 cfm) bathroom fans with a sound rating of 1.5 Sones or less.
- Provide a kitchen range hood, high-quality, 760 mm (30 in.), white finish, ducted directly to the HRV unit. No exhaust shall vent into the interior of the unit. Fan's capacity to be a minimum of 100 L/s (200 cfm). The hood shall be equipped with a removable/washable filter and integrated light.
- Provide range hoods with two operable speed settings.
- Install quiet fans.
- Specify and install only ENERGY STAR-rated ventilating fans, including utility and inline fans.
- Provide inline blowers for extraction of washer and dryer vents in laundry facilities.

Note: This document is to be read in conjunction with the most current: "The Region of Peel Universal Accessibility Standards for Affordable Residential Properties" and "Crime Prevention Through Environmental Design" (CPTED) and/or any other document referenced in this document.

4.4.3 Ducts

- Design all ducting with straight, short runs, with few turns and a maximum efficiency of air flow.
- Design supports of sufficient strength and rigidity to suit loading and services, and ensure that the building's structure can safely support the resultant stress.
- Provide ducting of at least 100 mm (4 in.) diameter for bathroom fans. For longer runs, provide 150 mm (6 in.) diameter duct to improve air flow.
- Seal all duct joints with aluminum duct tape to prevent air, moisture and noise leakage.
- Ensure any duct running through unheated areas (mechanical space) is insulated and has all of its joints sealed with aluminum duct tape.
- Identify function and source of all ducts with stencilled lettering, 50 mm (2 in.) high, spaced at no more than 3 m (10 ft.) apart.
- Insulate all ducts that exhaust to or intake from the exterior of the building for a length of 1,800 mm (6 ft.) from the exterior wall as per OBC requirements.

4.4.4 Piping

- Ensure any metal type piping (copper, steel or cast iron) which passes through and/or is concealed in masonry or concrete is insulated and wrapped with a fire retardant material to prevent metal to masonry/concrete contact.
- Provide supports to secure pipes, prevent pipe vibration, maintain required slopes by proper adjustment, allow for expansion and contraction and avoid pipe to pipe contact.
- Design supports of sufficient strength and rigidity to suit loading and services, and ensure that the building's structure can safely support the resultant stress.
- Provide vertical pipe supports at all floors, or as directed by consultant, using steel expansion pipe clamps.

4.4.5 Energy Efficiency

- Consider domestic hot water with implementation of active solar technology in mechanical systems design.
- Provide high-efficiency (greater than 90 percent) domestic hot water tanks with back-up pumps.

4.5 Plumbing

The proponent shall:

- Design hydronic-type heating implementing high-efficiency, condensing-type boilers.
- Provide a back-up DHW pump for high-rise apartments.
- Provide DHW pumps with VSD.
- Provide anti-siphon, non-freeze hose bibs with lockable covers and adequately sized for the landscaped area(s) at all outdoor spaces and service areas (and rooftop areas when window washing provisions are required). This includes landscape maintenance and communal spaces.
- Refer to Section 3.3.2 for irrigation systems.
- Space hose bibs at a maximum of 30 m (100 ft.) apart to provide adequate coverage.
- Ensure water supply is separately metered to Peel Living or as per the Region's directive.

Note: This document is to be read in conjunction with the most current: "The Region of Peel Universal Accessibility Standards for Affordable Residential Properties" and "Crime Prevention Through Environmental Design" (CPTED) and/or any other document referenced in this document.

4.5 Plumbing cont'd

- Install backflow preventers as per OBC and Region of Peel requirements.
- Include pressure-reducing valves as per Region of Peel requirements.
- Provide and co-ordinate the location of access panels for servicing and maintenance.
- Ensure all copper piping, up to 65 mm (2 ½ in.) diameter, is a hard temper-type “L” copper pipe. Piping larger than 65 mm (2 ½ in.) in diameter to be type “K” hard copper.
- Allow for thermal expansion of piping and equipment. Provide expansion loops or joints on all main runs and all risers.
- Provide a pre-manufactured expansion joint(s) for all piping when crossing building’s expansion joints.
- Isolate pipes to control vibrations.
- Provide a clean-out on every third floor for accessing and cleaning plumbing stacks.
- Provide each dwelling unit with a main water shut-off valve for all plumbing fixtures on the water supplies.
- Ensure each hot and cold water supply fixture within the unit has an easily accessible isolated valve.
- Insulate all piping for each application (thermal protection, etc.) in accordance with the Ontario Plumbing Code and OBC requirements.
- Supply all insulation with a factory-applied vapour barrier wrap jacket or foil-back wrapping as required for each application.
- Finish piping insulation with a protective cover, painted and labelled for identification.
- Ensure all valves, unions and equipment (pumps, etc.) are tagged, labelled and documented.
- Provide rough-in for dishwasher(s) in all common room kitchens.
- Ensure kitchen and bath faucets are single lever-type/washerless fixtures.
- Provide 3 L dual flush valve toilets, insulation-lined tank and installed with a floor gasket. Toilets shall have the CSA label.
- Provide adjustable water mixing valves in laundry facilities.
- Provide hot and cold water to the slop sinks in the janitor/housekeeping rooms (refer to Section 5.9.5.8).
- Provide garbage chute wash down facilities with sanitizing and odour control.
- Install wall mounted sinks with manufacturer-specified mounting brackets (concealed preferred).
- Provide floor drains in public and barrier-free bathrooms.
- Provide bathtubs with integrated drain stops.

4.5.1 Water Efficiency

- Use water efficient fixtures.
- Specify water conservation devices including low-flow plumbing fixtures (shower heads, water closets, etc.).

Note: This document is to be read in conjunction with the most current: “The Region of Peel Universal Accessibility Standards for Affordable Residential Properties” and “Crime Prevention Through Environmental Design” (CPTED) and/or any other document referenced in this document.

4.6 Electrical

The proponent shall:

- Integrate transformers into the site plan creating minimal impact on the project's operational and functional needs.
- Locate transformers away from dwelling units.
- Ensure all electrical conduits are concealed (surface mounted conduits will NOT be permitted).
- Ensure electrical room is independent from all other spaces. Locate electrical room(s) in one area, adjacent to other service rooms and preferably accessible by a service corridor. Locate as far as possible from dwelling units.
- Not use incandescent type of lighting (special circumstances may be considered, but must be approved by the Region of Peel).
- Provide light fixtures that are cost effective and readily available from suppliers to facilitate future replacement and maintenance.
- Limit the number of types of light fixtures to facilitate future maintenance.
- Provide high-quality, high-impact, heat-resistant and non-yellowing plastic fixture lenses in appropriate fixture types.
- Provide a catalogue of all proposed fixtures to the Region of Peel for review and approval.
- Design lighting as an architectural element using coves and bulkheads for indirect lighting alone or in combination, for a warm and well-balanced lighting effect.
- Provide vandal-resistant light fixtures in exterior and public areas.
- Ensure units have overhead and wall-mounted fixtures with individual controls to illuminate all areas.
- Provide "toggle" type switches.
- Provide GFI receptacles/circuits as required by codes.
- Ensure all receptacles are 400 mm (1.5 ft.) minimum AFF (refer to Appendix C, Section 4.2.5 and Figure 30).
- Ensure all light switches and other controls are located between 900 mm (3 ft.) and 1,200 mm (4 ft.) maximum AFF (refer to Appendix C, Section 4.2.2 and Figure 30).
- Provide a dedicated circuit for each receptacle to avoid tripping when multiple appliances are used at the same time.
- Hardwire all smoke alarms with a battery back-up in series with either the kitchen or bathroom light switch. Ensure no interferences with HRV control connections.
- Provide integrated task lighting over the kitchen counter that is glare free and can be switched separately.
- Provide timers for site lighting.
- Recess light fixtures for ceilings in public corridors.
- Provide rough-ins for telecommunications equipment (computer, telephone, cable, etc.) and audio-visual (A/V) equipment in all common areas.
- Provide motion sensors for lighting control in garbage rooms and other service areas as required.
- Develop room data sheets with specification detail showing provisions required for each unit, common room and amenity spaces. To be approved by the owner.
- Ensure the Region of Peel metering requirements are met (refer to Appendix D).
- Ensure individual suite metering is built into the project design. Locations to be approved by owner and AHJ.

Note: This document is to be read in conjunction with the most current: "The Region of Peel Universal Accessibility Standards for Affordable Residential Properties" and "Crime Prevention Through Environmental Design" (CPTED) and/or any other document referenced in this document.

4.6.1 Energy Efficiency

- Specify ENERGY STAR-qualified low power lighting options for interior and exterior fixtures and lighting:
 - **In units:** Install high-efficacy luminaries with screw-in CFL bulbs, covered or reflector style.
 - **Indoor lighting for common areas:** Install T8 fluorescent lights in accordance with Power Light Density (PLD) according to the most current ASHRAE 90.1 requirements. Fixtures to be equipped with electronic ballasts.
 - **Exterior Lighting:** Install pole-mounted LED fixtures.
 - **Parking Garage:** Install high-efficacy T5 luminaries, above 60 lumens/watt.
- Utilize solar power systems for energy conservation and cost savings (photovoltaic exterior lighting).
- Provide motion detector activated or timer-controlled lighting for security and energy conservation.
- Implement energy efficient appliances (ENERGY STAR-rated) for cost savings and lower energy consumption.
- Make provisions for receptacles and switches to accommodate future ceiling fan installations.

4.7 Building Envelope

The proponent shall:

- Explore passive and active solar possibilities.
- Orient the building to maximize winter solar gain.
- Configure the building or incorporate shading devices to reduce solar gain during summer.
- Provide insulation values that exceed ASHRAE standards by at least 25 percent when applicable.
- Consider incorporating a “green” (vegetated) roof for at least 50 percent of the roof area (to moderate heat in summer and to insulate in winter).
- Consider using ENERGY STAR-rated (highly reflective), and high emissivity-type of roofing for a minimum of 75 percent of the roof surface.
- Use any of the following cladding materials: brick, stone, metal, pre-cast concrete, curtain and window wall.
- Use the preferred wall system, which is a brick veneer (good-quality clay brick) cavity wall with a concrete block back-up construction or a precast concrete with spray foam insulation and steel stud flooring.
- Ensure width for air/cavity space in masonry veneer walls exceeds OBC minimum requirements. Design to comply with CSA Standards.
- Ensure thermal values of exterior assemblies are at least 15 percent above the minimum requirements set by the OBC. Do not include this increase in calculating the requirements of the building HVAC system components.
- Prevent any or all thermal bridging conditions.
- Ensure the air/vapour barrier retardant system within the walls is continuous and installed on the warm side of the wall. Ensure that the location of the air/vapour barrier is not creating a vapour trap for concealed condensation. This is a critical element that will be monitored for compliance.
- Protect the air barrier and vapour retardant during construction to prevent damage.
- Align thermal mass of wall insulation with thermal breaks in door and window frames.
- Provide expanding foam insulation in all exterior wall applications where thermal protection is required (products to be approved by the Region of Peel).

Note: This document is to be read in conjunction with the most current: “The Region of Peel Universal Accessibility Standards for Affordable Residential Properties” and “Crime Prevention Through Environmental Design” (CPTED) and/or any other document referenced in this document.

4.8 Roof

The proponent shall:

- Design roof lines and slopes to accommodate proper drainage, reduce snow build-up and eliminate snow slides and icicle build-up that could threaten pedestrians during winter months.
- Select materials used in roof assemblies for compatibility with physical and thermal behaviour. Preference shall be given to the assemblies that are using materials having proven long life-cycle expectancies and low maintenance requirements.

4.8.1 Sloped Roofs

- Design sloped metal roofs to be used as decorative building features, ie. To disguise mechanical penthouse and enhance urban fit.
- Design sloped roofs to comply with OBC requirements. Do not design roofs with slopes lower than a 4:12 ratio.
- Water protection to the walls below must be considered
- Provide ample venting as required.

4.8.2 Flat Roofs

- Provide Thermoplastic Polyolefin (TPO) roof system or equivalent as approved by the Region of Peel.
- Provide adequate protection to exposed roofing systems (materials and surfaces) to compensate for the following negative effects:
 - Uplift forces due to wind, floatation, etc.;
 - Differential thermal movements;
 - Roof traffic due to servicing roof-mounted equipment, access to service room(s), window washing and maintenance; and
 - All work performed post roof installation.
- Provide a service walkway suspended on neoprene spacers.
- Design roof to prevent snow build-up around mechanical equipment and exhaust intakes.
- Make suitable allowance for differential movement between insulation, membrane, metal flashings, etc., due to temperature and moisture changes.
- Provide a protective railing at all maintenance walkways as per OHSA.
- Bridge any obstructions at walkway locations.
- Ensure suspended equipment requirements are met (refer to Section 5.2).

Note: This document is to be read in conjunction with the most current: “The Region of Peel Universal Accessibility Standards for Affordable Residential Properties” and “Crime Prevention Through Environmental Design” (CPTED) and/or any other document referenced in this document.

4.9 Windows/Doors/Finish Hardware

The proponent shall:

4.9.1 Window Design

- Design windows and incorporate them in the building elevation in such a way that they are complementary, by avoiding a “tacked-on” appearance.
- Recess windows into the building’s façade to create a more solid expression and to increase shadow lines for visual interest.
- Design windows with mullions (horizontal and vertical dividers) as an architectural feature. Consider what impact the placement of mullions will have on views to the exterior from both the sitting and standing positions.
- Provide awnings or casement windows. NO sliders allowed.
- Design window heads flush with ceilings and jamb flush with walls.
- Design size of window openings to be relative and adequate for room’s intended use.
- Design windows to accommodate light and privacy control accessories.
- Provide window frames that are anodized aluminum, with colouring to suit building’s appearance.
- Provide framing that is thermally broken and has provisions for internal drainage to exterior.
- Provide windows with above-average ratings for the air filtration, water penetration, strength (from wind load) and energy efficiency.
- Provide argon-filled, sealed units with Low-Emissivity (Low-E) glass as per Region of Peel minimum standards; location of Low-E glazing to be determined on the basis of highest cost benefit return for the project.
- Provide all exterior windows with a minimum of double-glazed, sealed units with 6 mm (1/4 in.) thick outer pane.
- Provide sills with drips clear of wall cladding and with sill deflectors.
- Ensure window sills/stools are constructed out of a mould-resistant material or cultured marble.
- Provide proper weather seal between framing of opening and wall.
- Match the colour of the thermal spacers to the window frame.
- Provide rotary crank system operating components.

4.9.1.1 Energy Efficiency

- Provide windows that are tested and certified by the CSA.
- Ensure windows meet or exceed the following CSA A440-00 2000 criteria or the most current version:
 - Air tightness level
 - A2 – 1.65 (m³/h)/m
 - Water tightness level
 - B2 – 151-200 DRWP, Pa
 - Wind load resistance level
 - C3 – >2.0-3.0 kPa (blowout test pressure)

Note: This document is to be read in conjunction with the most current: “The Region of Peel Universal Accessibility Standards for Affordable Residential Properties” and “Crime Prevention Through Environmental Design” (CPTED) and/or any other document referenced in this document.

4.9.1.1 Energy Efficiency cont'd

- Energy rating level
- ER-26
- Proportion windows according to building orientation (maximize natural light/minimize need for artificial lighting).
- Provide windows of at least double-glazed units (minimum requirement).
- Incorporate cross ventilation where possible.

4.9.2 Door Design

- Design doors and incorporate them in the building elevation in such a way that they are aesthetically complimentary.
- Exterior exit doors, in apartment type of buildings, shall open onto a concrete slab or pre-manufactured concrete paving.
- Exterior door(s) of vestibule to be a heavy duty, commercial grade, aluminum type of door. They shall be power operated slider doors with a motion detection sensor system for its operation, and an auto-lock feature.
- Grade related exterior exit doors to be an insulated metal type of doors, in compliance to CAN/CGSB standard.
- Doors' thermal value to meet or exceed OBC and/or any applicable standard requirements.
- Exterior solid core: paint or stain grade, metal clad or hardwood faces, all six faces factory primed.
- Doors to be equipped with a heavy duty weather-stripping and metal covered door sill.
- All doors shall be installed with a good quality weather-stripping, metal covered threshold and heavy-duty kick plate.
- All door widths shall be as per the Region's Universal Accessibility Standards.
- Main entrance doors to dwelling units shall have a door viewer at 1,200mm from the floor.
- Emergency exit doors shall not have any exterior hardware or glazing.
- Overhead doors, such as underground parking access door, shall be insulated metal panels type door with formed steel guides, electrically operated (door opener) and be weather tight.
- Ensure through design and implementation that air/vapour barrier systems are continuous and integral to door frame assemblies.
- Proximity access card (fob) to be implemented for all residential units.
- Interior doors, semi-solid core or solid core only.
- NO decorative laminate finishes.

4.9.3 Finish Hardware

- Provide heavy-duty hardware meeting all applicable standards. Doors and door hardware in fire-rated assemblies (openings) shall meet fire-rated standards of certification (ULC).
- Provide hardware, including door closures, handles, etc., that meet all current barrier-free design standards (refer to Appendix C, Section 1.4).
- Ensure all door hardware preparation is done in factory.

Note: This document is to be read in conjunction with the most current: "The Region of Peel Universal Accessibility Standards for Affordable Residential Properties" and "Crime Prevention Through Environmental Design" (CPTED) and/or any other document referenced in this document.

4.9.3 Finish Hardware cont'd

- Ensure all keying is done by the contractor and the final set of keys is provided to the Region.
- Ensure all hardware is of commercial grade.
- Provide heavy-duty, high-quality door stops.
- Ensure all barrier-free units have an automatic door operator with appropriate push button and key switch or fob.
- Provide low profile thresholds (i.e. lower than OBC requirements) (refer to Appendix C, Section 1.4.5).
- Provide variable-speed door closures.
- Provide Mini Hartford metal/cast aluminum door numbers and plates manufactured by Whitehall or an owner-approved equivalent. Door numbers are to be centred within the door width at a height of 1,800 mm (70 in.) from the ground to the top of the plate using tamper-proof membrane screws. Colours to be approved by the owner.

4.10 Keying System

The proponent shall:

- Provide to the Region all master keys as per its requirements.
- Co-ordinate a meeting between the Region, the contractor and manufacturer to finalize requirements.
- Provide a keyless entry system using fobs.
- Provide a keying system and cabinets as determined and approved by the Region and/or Peel Housing Corporation.
- Register keys to Peel Housing Corporation or as directed by the Region.
- Deliver removal tool and master keys by registered mail to Peel Housing Corporation or as directed by the Region.
- Provide master keys that include, but are not limited to the following:
 - Suite Entrance locks: Eight keys
 - Grand Master keys: Eight keys
 - Sub-master keys: Eight keys
 - Staff Master keys for each group: Eight keys
 - Service Room Master keys: Eight keys
 - Construction Master keys: 12 keys
 - Four fobs per suite
 - All stamped for identification and delivered in a coded file-type cabinet with index binder.
 - All suite entrance keys are to remain in factory-sealed envelopes in possession of construction superintendent.
 - Provide all suite entrance lock keys differently and master keyed to a recorded system by the lock manufacturer.
 - Provide master and sub-master keys upon consultation with the Region of Peel.
 - Provide keyed alike group 1AA to operate all public or tenant activity rooms (e.g. activity room, storage locker room, laundry room, etc.), all entrance rooms to building and garage, and all other rooms requiring tenant access.

Note: This document is to be read in conjunction with the most current: "The Region of Peel Universal Accessibility Standards for Affordable Residential Properties" and "Crime Prevention Through Environmental Design" (CPTED) and/or any other document referenced in this document.

4.10 Keying System cont'd

- Provide a separated keyed alike 2AA to operate all building service rooms. (e.g. entrances, janitor's rooms, machine rooms, mechanical rooms, electrical rooms, store rooms) and to all rooms that require lock-out during servicing or off periods (i.e. recreation room/activity rooms, laundry, etc.).
- Common rooms shall be keyed differently and master keyed.
- Hydro meter room shall comply with local Hydro keying regulations. Otherwise provide a separate key and include in service master.
- Building entry key shall open any side entry doors.
- Provide two parking garage keys per number of suites and five spares.
- Mailroom entry door lock shall be provided and installed by the contractor, as supplied by Canada Post.

4.10.1 Key Control Cabinets

- Provide a lockable key control cabinet with a coded file and index binder.
- Provide one cabinet to accommodate all suite keys plus 10 percent extra.
- Ensure cabinets are manufactured by Lund or an equivalent approved by the Region of Peel.

4.11 Materials/Finishes

The proponent shall:

- Ensure all innovative materials with no proven construction industry record are reviewed and approved in writing by the Region.
- Limit using an extensive variety of materials in order to reduce the complexity of future maintenance.
- Ensure any exterior metal, exposed directly to the elements, is corrosion-resistant and protected:
 - Exposed steel (structural and non-structural) shall be galvanized with a factory-applied zinc coating protection.
 - Miscellaneous steel components such as railings shall be powder-coated or painted.
 - Exposed vents, grills, vent stacks, down-pipes, etc., shall have a factory-applied finish.
- Ensure metal chain link wire fencing is made of industrial grade galvanized metal, minimum 9 gauge, with exterior plastic-coated finish.
 - Fence corner posts to be a minimum of 76 mm (3 in.) in diameter and secured in the ground with a concrete base for stability.
 - Provide a top, middle and bottom horizontal rail throughout.
 - Use appropriate length screws to avoid cutting screws. Ensure a maximum of two threads protrude from nut.
 - Gate to be double swing for easy access for maintenance. Provide a middle latch to secure the gate in the ground.
- Ensure exterior concrete, exposed to weather elements, is air-entrained at minimum 6.5 percent and with a minimum compressive strength of 25 Mpa. In addition, the Region reserves the right to add colouring or tinting agents as required.
- Use products that are safe and respectful of the environment.

Note: This document is to be read in conjunction with the most current: "The Region of Peel Universal Accessibility Standards for Affordable Residential Properties" and "Crime Prevention Through Environmental Design" (CPTED) and/or any other document referenced in this document.

4.11 Materials/Finishes cont'd

- Promote use of durable, aesthetically pleasing and resilient products.
- Apply sufficient paint coats to achieve adequate coverage and uniform sheen.
- Provide colour boards for review and sign-off by the Region prior to installation.
- Allow the Region of Peel the opportunity to inspect and approve a completed mock-up unit before work proceeds with the remainder of the units. This completed unit will be signed off by the owner, contractor and architect, setting the standards for quality of workmanship and finishing criteria.
- Ensure all finished sub-floors are levelled with a self-levelling compound that provides an even floor finish.
- Ensure all drywall joints are taped, plastered, sanded and skimmed such that the joints are not visible after painting.
- Ensure all walls and ceilings are true and plum, free from waves and visual imperfections. The Region of Peel reserves the right to instruct any such deficiencies to be fully remediated.

4.12 Acoustical

The proponent shall:

- Ensure sound transmission classes meet or exceed the OBC requirements:
 - Between residential units: Minimum STC 52
 - Between residential units and other (non-residential) spaces: Minimum STC 55
 - Between residential units and mechanical or electrical rooms, emergency generator room, elevator room and/or elevator shaft (hoist way), any service room and refuse chute: Minimum STC 60
- Design layout to minimize noise conflicts between public, service and private areas, both on the interior and exterior sides.
- Ensure all party/demising walls between units are block masonry or concrete.
- Ensure acoustical requirements for floors exceed OBC requirements. Preference is to use “gypcrete”-type sub-flooring or an owner- approved equivalent.
- Isolate all drains, including roof drains.

4.13 Architectural Millwork

The proponent shall:

- Provide mock-ups for all suite millwork as per Section 4.11.
- Provide testing and inspection services in accordance with the guidelines of the AWMAC.

Note: This document is to be read in conjunction with the most current: “The Region of Peel Universal Accessibility Standards for Affordable Residential Properties” and “Crime Prevention Through Environmental Design” (CPTED) and/or any other document referenced in this document.

4.14 Equipment/Furnishings

The proponent shall:

4.14.1 Equipment

- Provide a parking control system integrated with suite entry fobs.
- Provide fall protection as per Section 3.2.3
- Ensure no scissor lifts are used in the building garbage rooms or loading areas.

4.14.2 Furnishings

- Provide and install window coverings for public areas.
- Carry an allowance for the supply and installation of furniture in public areas and common rooms selected by the Region. The owner will provide specification during the design stage.
- Be responsible for receipt, storage, placement and installation of all furnishings and decorative items.

4.15 Specialties

The proponent shall:

- Security mirrors in elevators, corridors and the underground garage.
- Corner guards in all common areas.
- Toilet partitions in public washrooms with more than one stall.
- Security cameras for main floor entrance, common areas and underground garage.
- A baby change table in all public washrooms (refer to Appendix C, Section 2.4.11).

Note: This document is to be read in conjunction with the most current: The Region of Peel Universal Accessibility Standards for Affordable Residential Properties” and “Crime Prevention Through Environmental Design” (CPTED) and/or any other document referenced in this document.

5.0 Design



5.1 OBJECTIVE

To create a residential environment that is safe and free of perilous conditions and provides a sense of security to residents and visitors while meeting quality design expectations that promote good energy conservation practices, environmental integration, universal accessibility, pedestrian movement, vehicular functionality and sustainable design considerations. Furthermore, to ensure that the context of the design is consistent with urban design requirements and addresses neighbourhood and community impacts pursuant to harmonious integration.

5.2 Safety

The proponent shall:

- Incorporate the principles of CPTED into the design.
- Design the project to eliminate potentially unsafe conditions.
 - Incorporate an adequate amount of lighting in compliance with the OBC and industry standards in both public and private areas and avoid designing secluded space(s) that could pose a threat to security.
- Design exterior circulation routes in a manner that prevents the creation of areas that lead to potential confusion, entrapment, dead ends or hidden spaces.
- Design life safety systems to comply with AHJ and applicable standards and codes.
- Hardwire all smoke alarms (refer to Section 4.6).
- Ensure all “Exit” lights are LED-type and securely mounted on walls or ceilings above exit doors, where required.
- Install building sprinkler system as per OBC requirements.
- Ensure elevator rooms have guards installed to protect against moving equipment as per OSHA requirements.
- Install sufficient anchor for mounting systems necessary to ensure the safety requirements for suspended equipment and rolling stages normally used for (but not limited to) window cleaning operations, general cleaning, repair, painting, maintenance, inspection and construction operations and similar work are met.

5.3 Security

The proponent shall:

- Ensure the project design reflects the current CPTED principles as identified in the Region of Peel CPTED Policy; Resolution 98-1029 (see attached link in Appendix F).
 - CPTED principles shall be incorporated in all phases of the project’s design, review and approval.
- Design the building to create a sense of natural surveillance.
 - Windows of dwelling units to overlook public and semi-private outdoor spaces.
 - Landscaping is to be designed in such a manner to avoid mature growth that blocks site lines around the building.
- Equip all building entrances with an entry system controlled from individual suites with provisions for communication and video capacity.

Note: This document is to be read in conjunction with the most current: “The Region of Peel Universal Accessibility Standards for Affordable Residential Properties” and “Crime Prevention Through Environmental Design” (CPTED) and/or any other document referenced in this document.

5.3 Security cont'd

- Install surveillance cameras and alarm signal devices at:
 - Exterior of building entrance(s)
 - Remote building corners
 - Front lobby of the building
 - Concealed areas
 - All building exits
 - Entrances and corners of the parking garage
- Provide adequate lighting at public and private secluded areas.

5.4 Lighting

The proponent shall:

- Design project to follow the CPTED principles.
- Design lighting to meet project's requirements, by adopting appropriate design features that will deter crime and contribute to quality of life.
- Provide direct lighting over walkways, entrances and patios.
- Ensure light fixtures are vandal-resistant, of sturdy construction and low maintenance.
- Design fixtures to accommodate CFL lighting.
- Design lighting locations to adequately illuminate parking area(s), parking drop-offs and every location of entry to the building.
- Ensure the maximum Candela value of all interior lighting, as per OBC requirements, falls within the building (not out through windows). Similarly, the exterior lighting is to fall within the property.
- Consider shielding exterior luminaries with more than 1,000 initial lamp lumens, and all luminaries with more than 3,500 initial lamp lumens must meet the full cut-off IESNA Classification to reduce light pollution.
- Use fixtures that do not create shadows or excessive glare across walking areas, ramps and stairs.
- Ensure lighting levels are uniform along pedestrian routes.
- Ensure fixtures are non-institutional in appearance.
- Avoid use of high-intensity wall packs.
- Use light-sensitive control devices (photocells) to reduce electrical power consumption. Consider using motion-sensitive controls where practical.
- Control light coverage through lighting accessories (baffles, cut-off luminaries, shades, low-reflective surfaces, etc.).
- Use high-efficiency light fixtures that are ENERGY STAR-qualified (refer to Section 4.6.1).

5.5 Balconies

The proponent shall:

- Not design balconies in affordable housing design.

Note: This document is to be read in conjunction with the most current: "The Region of Peel Universal Accessibility Standards for Affordable Residential Properties" and "Crime Prevention Through Environmental Design" (CPTED) and/or any other document referenced in this document.

5.6 Accessibility

The proponent shall:

- Design all projects in accordance with the latest version of the Region's UAS for Affordable Residential Properties (refer to Appendix C).
- Design site plan content to be approved by the Region's AAC through a formal hearing presentation. In addition, all accessibility content throughout the building will be included in this review.
- Ensure the more stringent standard prevails where conflicts arise between the following requirements and the Region's UAS, Appendix C.
- Minimize level changes on pedestrian circulation routes.
- Ensure access to all amenities areas is barrier-free including door width and automatic door opener.
- Provide a barrier-free drop-off area located in close proximity to the main entrance of the building.
- Design ramps to the OBC and CAN/CSA requirements and standards:
 - Maximum slope of 1:12.
 - Provide handrails on both sides of ramp(s).
- Provide paving and curb cuts as required, but not limited to the following:
 - Provide coloured paving, adjacent to curb cut with a sufficiently contrasting colour, preferably yellow.
 - Depressed curb areas and/or sidewalk are to have visual contrasting colour sufficient to provide awareness of grade change.
 - Flare sides of curb cuts. Slope not to exceed 1:3 ratio.
 - Provide a minimum width of 1,067 mm (42 in.) for curb cuts/ramp.
 - Provide textural change on curb cuts and adjacent walkway area.
 - Provide a lip flush with the pavement.
 - Walkways shall be adequately drained with a minimal number of drain gratings.
 - Provide proper sub-base to minimize excessive settling and level changes in walkways. Inspection and testing of compaction will be mandatory.
 - Use of rough or unstable materials for walking surfaces shall not be permitted.
 - Do not create hazardous surfaces and unanticipated changes in level conditions (e.g. drops, tripping hazards, sudden edges).
- Construct sloped concrete surfaces of a non-slip surface (sand float or broom finished) with brushing perpendicular to slope.
- Weather protect exterior ramps with an integral snow melting system. The Region of Peel to determine need.
- Provide 50 mm (2 in.) high curbs on sides of ramps to act as wheel guards.
- Consider designing planters that will permit barrier-free travel to the garden. Minimum planter height 600 mm (2 ft.); if deeper than 600 mm (2 ft.) then they shall be accessible from both sides.

Note: This document is to be read in conjunction with the most current: "The Region of Peel Universal Accessibility Standards for Affordable Residential Properties" and "Crime Prevention Through Environmental Design" (CPTED) and/or any other document referenced in this document.

5.7 Outdoor Storage

The proponent shall:

- Within the building, provide an outdoor storage room with a minimum size of 7 m² (75 sq.ft.). Storage room shall have the following features:
 - Access from the outside
 - Block or concrete wall with epoxy paint
 - Appropriate drainage
 - Appropriate ventilation and heating
 - T5 lighting
 - Minimum of 1 power receptacle
 - One hose bib
 - 914 mm (36 in.) single metal door
 - Lockable hardware

5.8 Entrances/Exits

The proponent shall:

5.8.1 Main Entrance (Lobby)

- Provide an entry vestibule with protection from weather elements by recess or a detailed and finished canopy.
- Provide private telephone intercom system. Rental telephone system is not acceptable.
- Ensure main entrance has a camera that allows for monitoring from the television cable system within each suite.
- Provide a well-illuminated, energy-efficient lighting scheme.
- Provide a drop-off area that is entirely visible from lobby area.
- Create a sense of entry with distinctive identity by placing a wall-mounted, decorative mirror feature at the entrance to provide a focal point. This mirror shall include the project's name and/or logo etched into it. Mirror size and style to be determined by the Region of Peel.
- Place a corner stone at the main entrance of the building with the year of completion.
- Provide foot grills for both exterior and interior entrance areas.
- Ensure interior main entrance has proximity scanners to trigger auto door opener.
- Provide built-in seating that is comfortable, durable and vandal-resistant.
- Minimize furniture to discourage loitering.
- Provide a mailroom area with exterior access by Canada Post.
- Maximize use of natural daylight for direct exterior lighting where possible.
- Locate windows/skylights in a manner that avoids creating glare.
- Locate manager's office within sight of front lobby area and elevator(s).
- Provide a glassed-in bulletin board located adjacent to superintendent office.
- Ensure entrance lobby has decorative flooring and ceiling design pattern.

Note: This document is to be read in conjunction with the most current: "The Region of Peel Universal Accessibility Standards for Affordable Residential Properties" and "Crime Prevention Through Environmental Design" (CPTED) and/or any other document referenced in this document.

5.8.2 Suite Entrances

- Align entry doors to suites on both sides of the building corridor where possible.
- Design suite entrances to establish sense of arrival and personalization by using a different flooring pattern or colour.
- Ensure suite entrances are safe, secure and well illuminated.
- Ensure suite entrances have a recess of 300 mm (1 ft.) deep, 2,150 mm (7 ft.) high and 1,500 mm (5 ft.) wide.
- Ensure suite recessed entrances have overhead valence lighting. LED or pot lighting is optional upon the Region of Peel's approval.
- Provide suite numbering and signage as determined by the Region of Peel (refer to Section 4.9.3).
- Provide for the purpose of universal accessibility, all units with a door viewer mounted at 1,200 mm (4 ft.) from the floor (refer to Section 4.9.2).

5.8.3 Exits

- Ensure exits are well lit and defined.
- Minimize blind corners, niches and possible hiding places.
- Provide security mirrors.
- Locate exit signs above every stairwell exit and in compliance with OBC and Fire Code.

5.9 Public Spaces

The proponent shall:

5.9.1 Corridors

- Ensure corridor width is a minimum 1,800 mm (6 ft.).
- Incorporate a handrail on at least one side of the corridor as per the Region of Peel Universal Accessibility Standards for Affordable Residential Properties (refer to Appendix C, Section 1.8).
- Design corridors to minimize blind spots and possible hiding places.
- Provide visual relief through wall treatment, patterned flooring and ceiling finishes.
- Maximize use of natural daylight for lighting where possible.
- Not install any light switches in the hallways.
- Provide corner guards.
- Lock out thermostats located in public areas by programming or installing non-tamper covers.
- Not design long and monotonous corridors.
- Provide a motion sensor on every other light fixture.

Note: This document is to be read in conjunction with the most current: "The Region of Peel Universal Accessibility Standards for Affordable Residential Properties" and "Crime Prevention Through Environmental Design" (CPTED) and/or any other document referenced in this document.

5.9.2 Stairs

- Provide painted metal railings designed to meet OBC requirements. Confirm design specifics with the Region of Peel.
- Ensure stairs are painted precast with non-slip finish and recessed carborundum strips (refer to Appendix A, Finishes Schedule and Appendix C, Section 1.7 and Figure 12).
- Provide natural daylight where possible.

5.9.3 Elevators

- Design elevators to meet the OBC, CAN/CSA and TSSA requirements and standards.
- Ensure elevator equipment is non-proprietary.
- Design elevator cabs to be barrier-free and large enough to accommodate a minimum of two wheelchairs (refer to Appendix C, Section 1.9).
- Provide at least one elevator in seniors' buildings regardless of height of building.
- Locate elevators in sight of superintendent's office if possible.
- Provide extended two-year warranty/service agreement.
- Provide floor indicator display at each level.
- Fit both sides of each interior cab with jamb-mounted direction indicator lamps.
- Ensure illuminated metal control call button is flush mounted and vandal proof.
- Ensure service elevator has a key-operated rear-access door to the moving room and sized to accommodate a 2.3 m x 1.8 m (7.5 ft. x 6 ft.) stretcher.
- Recess elevator lobby from the corridor to allow for easy flow of traffic.
- Provide copies of TSSA elevating device license(s) and certificate(s).
- Incorporate a recessed seating bench with planters on each side and pot lights above in elevator lobbies to allow for comfortable waiting.
- Ensure elevator lobby area has additional lighting to enhance a visual presence.
- Ensure elevator lobby has porcelain or quarry flooring with a non-slip surface and a contrasting colour from corridors.

5.9.3.1 Elevator Finishes

- Ensure cab has removable decorative ceiling to match cab walls and to allow for easy servicing.
- Provide stainless steel inserts with decorative stainless steel ceiling panels.
- Provide well-illuminated cabs with LED light fixtures.
- Ensure elevator car doors, wall panels, entrance doors, handrails, base and reveal trim are Rimex or Rigid-Tex-type 304 stainless steel in 16 gauge, stainless steel Pippin finish (#4 finish), or equivalent approved by the Region of Peel.
- Provide all elevator cabs with convex mirrors for security.
- Locate handrails at barrier-free height.
- Ensure elevator cab flooring is porcelain tile with non-slip textured surface.

Note: This document is to be read in conjunction with the most current: "The Region of Peel Universal Accessibility Standards for Affordable Residential Properties" and "Crime Prevention Through Environmental Design" (CPTED) and/or any other document referenced in this document.

5.9.3.1 Elevator Finishes cont'd

- Ensure elevator control buttons address a variety of functional issues such as reach, dexterity and visual impairments. They shall be compliant with TSSA, CSA, OBC, Region of Peel UAS and other AHJ.
- Ensure elevators provide audible cues, as well as adequate door closing delays.
- Equip elevators with phone line and provisions for card/proximity card reading device controls.
- Provide moving pads/cab protection with all required hardware.
- Provide all proprietary tools at the completion of warranty.

5.9.4 Common Areas

5.9.4.1 Common Room (Lounge)

- Provide dimmable pot lighting throughout room(s) on multiple circuits.
- Provide a dedicated circuit for each receptacle to avoid tripping when multiple appliances are used at the same time.
- Provide a storage space adjacent to or part of the room, which allows for storage of spare furniture.
- Ensure sound attenuation of the common room areas is a minimum of 60 STC rating.
- Provide a coat closet.
- Ensure common areas are air conditioned.
- Provide intercom with remote release of main entrance door.
- Provide conduit and cable outlets for both floor and wall-mounted televisions.
- Provide conduit, cable and receptacles for telephone and data cabling.
- Equip kitchen (or kitchenette) with:
 - A 30 in. stove (refer to Section 5.10.3.4 for additional requirements)
 - A 22 cu.ft. refrigerator with bottom mount freezer (refer to Section 5.10.3.4 for additional requirements)
 - A 10 in. deep double sink
 - A 24 in. width, white, ENERGY STAR-rated, built-in residential-type dishwasher with nylon racks and a minimum of four cycles to include light, normal, pots/pans and rinse cycle. Models to be reviewed and approved by the Region of Peel.
- Ensure countertops for communal kitchens are cultured marble or solid surface as selected by the Region of Peel.
- Refer to Appendix B for common room kitchen millwork with the exception of countertop finish and depth of sink.
- Provide a barrier-free washroom within the space.
- Provide roller shades on all windows.

Note: This document is to be read in conjunction with the most current: "The Region of Peel Universal Accessibility Standards for Affordable Residential Properties" and "Crime Prevention Through Environmental Design" (CPTED) and/or any other document referenced in this document.

5.9.4.2 Bicycle Room

- Provide bicycle room located on the main floor with direct access to outside (provide ramp if required).
- Provide one spot for every three suites for family buildings and one spot for every five suites for seniors' buildings.
- Provide hardware for hanging, securing and storing bicycles.
- Provide vertical bicycle racks in family buildings and floor-mounted bicycle racks in seniors' buildings.
- Provide adequate ventilation.
- Provide motion-sensor lighting.
- Ensure room is lockable.
- Provide security cameras at the entrance and in the room.
- Provide a time-delay door closer

5.9.4.3 Mail Room/Boxes

- Refer to the current Canada Post requirements (see attached link in appendix F).
- Refer to current Region of Peel Universal Accessibility Standards for Affordable Residential Properties in Appendix C, for requirements.
- Provide provision for parcel/mail pick-up. Install a mail outbox with a slot for Canada Post to collect outgoing mail where applicable.
- Integrate mail access for residents into the main lobby area with access for mail delivery directly from the exterior.

5.9.5 Support and Service Areas

5.9.5.1 General

- Design support and service areas to be durable, easily maintained and well serviced by the mechanical and electrical systems.
- Provide a minimum of 60 STC rating for walls, floors and ceilings.
- Provide a scooter room in seniors' buildings. This room shall be of a minimum size of 3.7 m x 6.1 m (12 ft. x 20 ft.) and it shall include the following features:
 - Impact-resistant drywall at a minimum height of 1,500 mm (5 ft.) AFF
 - Porcelain tile floor finish
 - Porcelain tile dado at a minimum of 1,200 mm (4 ft.) AFF
 - Appropriate ventilation system
 - Door with a side window for security
 - Battery charging station
 - Appropriate HVAC
 - Sprinkler system
 - Fire rated walls and door
 - T5 lighting

Note: This document is to be read in conjunction with the most current: "The Region of Peel Universal Accessibility Standards for Affordable Residential Properties" and "Crime Prevention Through Environmental Design" (CPTED) and/or any other document referenced in this document.

5.9.5.2 Storage

- Provide a 23 m² (250 sq.ft.) secure, heated and ventilated storage room located in the basement or ground floor.

5.9.5.3 Laundry Room

- Provide a keyless entry system using fobs with capability for programmable time of use.
- Locate at ground floor level with access to an outdoor secured child play area (family building) or amenity area (refer to Section 3.3.1).
- Design laundry room equipment in accordance with Peel Living's laundry concession vendor.
- Confirm ratio of equipment to units with the Region of Peel.
- Provide individual ventilator and fan for each gas dryer and exhaust to the building exterior in the shortest distance possible.
- Ensure each dryer has a separate disconnect valve.
- Provide a fresh air intake system.
- Provide a phone line and a power outlet for a debit machine in laundry room.
- Connect water supply for washing machines to the main domestic hot water system.
- Provide a separate drain for cleanout on each washing machine.
- Provide air conditioning to the room.
- Provide window(s), complete with roller shades.
- Provide a clothes folding counter/table with dual height to accommodate accessibility requirements.
- Refer to Appendix B for laundry room millwork detail.
- Provide a barrier-free washroom within the space.
- Provide a notice/bulletin board.
- Provide seating.
- Provide floor drains with appropriate slopes.

5.9.5.4 Garbage Room

- Design garbage room in accordance with Regional Waste Management standards (refer to References section).
- Locate garbage room away from the building entrance(s) and air intake ducts.
- Provide exhaust fan within the room on a programmable timer.
- Reduce exposure from public roads or main entrance.
- Protect and design walls and floor with finishes suitable for garbage rooms and to accommodate heavy equipment (refer to Appendix A).
- Ensure floor finish is slip-resistant, preferably epoxy-based floor coating or equivalent (refer to Appendix A).
- Provide wash down areas with drains.

Note: This document is to be read in conjunction with the most current: "The Region of Peel Universal Accessibility Standards for Affordable Residential Properties" and "Crime Prevention Through Environmental Design" (CPTED) and/or any other document referenced in this document.

5.9.5.4 Garbage Room cont'd

- Provide a stainless steel slop sink with provision for hot and cold water, including a ceramic tile dado around sink area.
- Not use drywall; cement board or equivalent shall be provided.
- Locate the compactor and garbage chute to allow for convenient access on both sides of the compactor for maintenance and operations staff.
- Provide sanitizer system with odour control for the garbage chute maintenance that is accessible and easy to operate.
- Provide an easy access route for the garbage trucks to pick up garbage bins.
- Ensure garbage approach and pick-up area is level, heavy-duty concrete slab and large enough for the placement of garbage bins (containers).
- Provide a metal or concrete safety curb to prevent garbage bins from rolling away.
- Provide glycol or electric heating in the exterior garbage area concrete pad.
- Provide a garbage compactor.

5.9.5.5 Recycling Room

- Locate adjacent to garbage room.
- Provide direct access to outdoor for container pick-up.

5.9.5.6 Garbage Chute Room

- Locate garbage chute room(s) centrally on each floor.
- Avoid locating garbage chute room opposite to a residential suite entrance door.
- Provide exhaust fan within the room on a programmable timer.
- Provide a dual-sorter in each garbage room for recycling and garbage.
- Design garbage chute room to be barrier-free.
- Provide automatic door opener on all floors.

5.9.5.7 Moving Room

- Locate the moving room away from the building entrance(s) if possible and in close proximity to the service elevator.
- Ensure exterior doors are heavy-duty with heavy-duty hinges, door closers and hold-open devices or an overhead door.
- Protect interior and exterior door jambs with bollards.
- Provide corner guards.
- Heat and ventilate room through the building's main system.
- Ensure floors have a non-slip, heavy-duty finish.
- Provide a storage room adjacent to the moving room with a lockable door.

Note: This document is to be read in conjunction with the most current: "The Region of Peel Universal Accessibility Standards for Affordable Residential Properties" and "Crime Prevention Through Environmental Design" (CPTED) and/or any other document referenced in this document.

5.9.5.8 Janitor and Housekeeping Closets

- Provide a minimum of four housekeeping closets in the building.
- Ensure room is 2.3 to 2.8 m² (25 to 30 sq.ft.) in area.
- Provide an eye wash station within the room.
- Provide adequate lighting and ventilation.
- Provide a terrazzo floor slop sink with provision for hot and cold water, including ceramic tile dado at sink area.
- Provide a non-slip floor (refer to Appendix A).
- Provide a floor drain with appropriate slope.
- Not use drywall; cement board or equivalent shall be provided.
- Provide shelves for storage.

5.9.6 Parking

- Provide a “parking strategy proposal” that includes provisions for tenants, visitors and barrier-free parking.
- Address allocation, design and any specific project requirements in the “parking strategy proposal.”
- Provide tenant parking in an enclosed structure; visitor parking shall be provided at grade.
- Design parking spaces to be separate and secure for seniors, families and visitors.
- Use landscaped islands to break up large parking areas for surface parking.
- Design parking area(s) not to conflict with children’s play or outdoor private spaces.
- Conform to the Region’s minimum acceptable parking requirements (not withstanding municipal requirements):

Parking Requirements			
	Resident Spaces	Visitor Spaces	Total
Family Dwelling Unit	1.00	0.25	1.25
Senior Dwelling Unit	0.50	0.25	0.75
Barrier-Free Parking	Spaces shall be calculated on 5% of total number housing units		

- Consider snow storage and removal when designing parking area(s) and access routes.
- Provide a hard surface area(s) for snow storage based on a minimum of 5 percent of the total parking area and in a location suitable for plough operation (pushing).
- Illuminate all outdoor parking areas.

Note: This document is to be read in conjunction with the most current: “The Region of Peel Universal Accessibility Standards for Affordable Residential Properties” and “Crime Prevention Through Environmental Design” (CPTED) and/or any other document referenced in this document.

5.9.6 Parking cont'd

- Direct illumination towards the paved areas only and not into dwelling units.
- Make provisions for pedestrian routes through parking area(s) with sightlines at intersections of walkways and vehicular traffic.
- Demarcate and provide appropriate lighting on pedestrian routes designed for use by wheelchairs, carriages and shopping carts.
- Locate parking spaces away from residential dwelling unit(s) (windows and doors) to avoid exposure to noise, exhaust fumes and headlight glare.

5.9.6.1 Barrier-Free Access Parking Spaces

- Refer to Appendix C, for the Region of Peel UAS for Affordable Residential Properties.

5.9.6.2 Underground Parking

- Provide adequate, secure, efficient and cost-effective parking with minimal land development impact.
- Consider placing a minimum 75 percent of the required parking spaces in the underground parking.
- Locate the points of entry/exit (ramps and doors) to the underground parking garage in close, convenient proximity to the drop-off zones.
- Ensure design provides an adequate headroom clearance. Provide a minimum of 2.5 m (8 ft.) headroom between the underside of the lowest sprinkler head and the highest point on the floor (concrete slab).
- Design parking with double-loaded aisles and, where possible, without dead ends.
- Install sprinklers throughout the entire parking garage as per OBC and OFC requirements.
- Extend dry sprinkler test lines and low points down to floor level and have end caps, as well as, provide protection from vehicular impact.
- Provide proper floor drainage.
- Provide a linear floor catch basin with grill at the base of all ramps.
- Protect all suspended and vertical surfaces within 900 mm (3 ft.) of splash zones from chloride-induced corrosion.
- Provide adequate sightline distances for all maneuvers under reasonable speeds.
- Provide adequate, energy-efficient lighting throughout the parking areas. Meet or exceed OBC minimum requirements for lighting and comply with Municipal guidelines and by-laws (refer to Section 4.6.1).
- Locate parking entrance(s) within sightlines of the building's main entrance and ensure they are well lit.
- Use colour coding and graphics to identify floors, stairwells and elevators, while also complying with relevant codes and Municipal bylaws.
- Refer to Interior Finishes Schedule, Appendix A.

Note: This document is to be read in conjunction with the most current: "The Region of Peel Universal Accessibility Standards for Affordable Residential Properties" and "Crime Prevention Through Environmental Design" (CPTED) and/or any other document referenced in this document.

5.10 Suite Requirements

The proponent shall:

5.10.1 General

- Design all units for maximum use efficiency with well-defined areas (individual rooms) and with allowance for sufficient wheelchair turning radius in each room.
- Include all in-suite storage and closets when calculating NFA.
- Design the units to provide a generous amount of exterior/natural light to make the units bright and inviting.
- Equip every unit with a programmable thermostat.
- Provide exterior views that connect to the public realm, while also retaining privacy.
- Ensure 10 percent of the total number of units are full barrier-free units.

5.10.1.1 Telephone/Cable TV

- Provide all rough-ins for cable TV including, but not limited to, outlets, cover plates, conduits and pull boxes.
- Provide cable and telephone rough-ins in living/dining room and master bedroom.
- Be responsible for wiring cable and telephone lines to each suite.

5.10.2 Room Relationships

- Create clear separation between public and private areas.
- Not locate, if possible, residential units next to service areas (including mechanical, electrical and laundry rooms).
- Provide direct exterior views for building occupants in 90 percent of all regularly occupied areas.

5.10.3 Private Areas

5.10.3.1 Unit Hallway

- Ensure minimum 1,100 mm (3.6 ft.) in width.
- Avoid creating long hallways.
- Provide direct natural light.
- Provide a storage room.
- Provide a linen closet with shelves.

Note: This document is to be read in conjunction with the most current: “The Region of Peel Universal Accessibility Standards for Affordable Residential Properties” and “Crime Prevention Through Environmental Design” (CPTED) and/or any other document referenced in this document.

5.10.3.2 Living/Dinning Area

- Combine dining room with living room.
- Provide an exterior window in the living room.
- Design space to accommodate the placement of various furniture types and arrangements.
- Avoid overlap with circulation space.
- Provide window(s) avoiding direct sightlines from immediate units and adjacent buildings.

5.10.3.3 Bedrooms General

- Design room layout to adequately accommodate bedroom furniture.
- Make provisions for a closet with a shelf and rod.
- Ensure closet doors open outward.

5.10.3.4 Kitchen

- Install kitchen upper cabinets to underside of bulkhead(s).
- Refer to Millwork Schedule, Appendix B, for cabinetry design.
- Provide refrigerators of the following sizes and features:
 - Units with 1 and 2 bedrooms to carry 17 cu.ft. refrigerator with top-mounted freezer
 - Units of 3 bedrooms to carry 18 cu.ft. refrigerator with top-mounted freezer
 - Units of 4 and 5 bedrooms to carry 20.5 cu.ft. refrigerator with top-mounted freezer
 - Barrier-free units to carry 22 cu.ft. refrigerator with bottom-mounted freezer
 - No ice makers in the refrigerators
 - ENERGY STAR-rated
 - White, reversible door
 - Frost-free freezer
 - Adjustable glass crisper shelves
 - Deep-fixed door bins
 - Magnetic door gasket
 - Wired shelves in freezer
 - Automatic moisture control
 - Removable egg cradle/bucket
 - Snack centre drawer
 - Sound silencing system

Note: This document is to be read in conjunction with the most current: “The Region of Peel Universal Accessibility Standards for Affordable Residential Properties” and “Crime Prevention Through Environmental Design” (CPTED) and/or any other document referenced in this document.

5.10.3.4 Kitchen cont'd

- Provide stoves of the following sizes and features:
 - Units with 1 and 2 bedrooms to carry 30 in. stoves
 - Units of 3, 4 and 5 bedrooms to carry 30 in. stoves
 - 2/6 in. and 2/8 in. elements
 - Removable chrome drip bowls
 - White in colour
 - Glass front oven door with light
 - Control lockout option for oven
 - Attached appliance outlet
 - No clock
 - Easy clean oven with two oven racks
 - Full size storage drawer
 - Safe-T elements by Pioneer technology
 - Barrier-free units to carry 762 mm (30 in.) stoves
 - Full barrier-free units to have a wall mounted oven and a cook top stove with controls at the front
- Not locate stoves adjacent to doorways or in corners.
- Provide minimum 350 mm (1.2 ft.) wide counter between stove and adjacent wall or appliance.
- Provide direct natural light whenever possible.
- Provide a pantry with 1,000 mm (3.3 ft.) x 1,800 mm (6 ft.) fixed shelving and a door that opens outward.
- Provide direct access from main entry area.
- Provide a pass-through when kitchen is separate from dining room.

5.10.3.5 Bathrooms

- Ensure bathrooms are spacious to allow for two-person occupancy simultaneously.
- Provide space for laundry storage (hamper).
- Provide a 3 L dual flush valve toilet (refer to Section 4.5).
- Ensure bathtub is 1,525 mm (5 ft.) long with non-slip surface and equipped with concealed drain.
- Consider providing a walk-in bathtub in 2 percent of total seniors' units.
- Provide pressure balancing mixing valve for diverter spout and shower.
- Ensure shower head is a low-flow, water-saving-type.
- Provide a minimum 900 mm (3 ft.) long vanity unit.
- Provide recessed or semi-recessed medicine cabinet. Mirror to be wall hung or part of medicine cabinet.

Note: This document is to be read in conjunction with the most current: "The Region of Peel Universal Accessibility Standards for Affordable Residential Properties" and "Crime Prevention Through Environmental Design" (CPTED) and/or any other document referenced in this document.

5.10.3.5 Bathrooms cont'd

- Equip all seniors' and barrier-free units with grab bars and necessary backboard (refer to Appendix C, Sections 2.1, 2.6 and 2.7).
- Ensure main bathroom in each family unit has backboards for future grab bar provision.
- Provide natural light whenever possible.
- Provide cement/green board on walls at bathtub and sink area. Ceiling above bathtub shall have cement board as well.
- Use mildew-resistant silicone caulking throughout.
- Avoid direct access (and view) from the main living areas.
- Ensure all bathrooms are accessible from the hallway. Ensuite bathrooms are not permitted.
- Provide exhaust fan (refer to Section 4.4.2).
- Ensure light switch is located on the outside of the bathroom.

5.10.4 One Bedroom

- Maximum NFA for the unit: 60.4 m² (650 sq.ft.)*
- Minimum NFA: 50.4 m² (542.5 sq.ft.), combined Living/Dining

As follows:

- Living Room – 14.0 m² (approx. 150.7 sq.ft.)
- Dining Room – 7.4 m² (approx. 79.7 sq.ft.)
- Kitchen (next to/with Living/Dining) – 7.5 m² (approx. 80.7 sq.ft.)
- Bedroom – 11.0 m² (approx. 118.4 sq.ft.)
- Bathroom – 3.7 m² (approx. 39.8 sq.ft.)
- Entrance Foyer – 1.6 m² (approx. 17.2 sq.ft.)
- Closets/Storage (total no shelving) – 5.2 m² (approx. 56 sq.ft.)

* Includes all internal circulation within the unit.

5.10.5 Two Bedrooms

- Maximum NFA for the unit: 79.0 m² (850 sq.ft.)*
- Minimum NFA: 59.4 m² (639.4 sq.ft.), combined Living/Dining

As follows:

- Living Room – 14.0 m² (approx. 150.7 sq.ft.)
- Dining Room – 7.4 m² (approx. 79.7 sq.ft.)
- Kitchen (next to/with Living/Dining) – 8.5 m² (approx. 91.5 sq.ft.)
- Bedroom (Master) – 11.0 m² (approx. 118.4 sq.ft.)

Note: This document is to be read in conjunction with the most current: "The Region of Peel Universal Accessibility Standards for Affordable Residential Properties" and "Crime Prevention Through Environmental Design" (CPTED) and/or any other document referenced in this document.

5.10.5 Two Bedrooms cont'd

- Bedroom (Additional) – 8.0 m² (approx. 86.1 sq.ft.)
- Bathroom (with vanity) – 3.7 m² (approx. 39.8 sq.ft.)
- Entrance Foyer – 1.6 m² (approx. 17.2 sq.ft.)
- Closets/Storage (total, no shelving) – 5.2 m² (56 sq.ft.)

* Includes all internal circulation within the unit.

5.10.6 Three Bedrooms

- Maximum NFA for the unit: 92.9 m² (1,000 sq.ft.)*
- Minimum NFA: 75.6 m² (814.0 sq.ft.), combined Living/Dining

As follows:

- Living Room – 15.3 m² (approx. 165 sq.ft.)
- Dining Room – 8.4 m² (approx. 90 sq.ft.)
- Kitchen (next to/with Living/Dining) – 11.2 m² (approx. 120 sq.ft.)
- Bedroom (Master) – 11.6 m² (approx. 125 sq.ft.)
- Bedroom (2 Additional) – totalling 16.7 m² (approx. 180 sq.ft.)
- Main Bathroom (with vanity) – 3.7 m² (approx. 40 sq.ft.)
- Powder Room (with basin) – 1.5 m² (approx. 16 sq.ft.)
- Entrance Foyer – 1.6 m² (approx. 17.2 sq.ft.)
- Closets/Storage (total, no shelving) – 5.6 m² (approx. 61 sq.ft.)

* Includes all internal circulation within the unit.

5.10.7 Four Bedrooms

- Maximum NFA for the unit: 111.5 m² (1,200 sq.ft.)*
- Minimum NFA: 85.8 m² (923.6 sq.ft.), combined Living/Dining

As follows:

- Living Room – 15.3 m² (approx. 165 sq.ft.)
- Dining Room – 8.4 m² (approx. 90 sq.ft.),
- Kitchen (next to/with Living/Dining) – 11.2 m² (approx. 120 sq.ft.)
- Bedroom – 11.6 m² (approx. 125 sq.ft.)
- Bedroom (3 Additional) – totalling 25.1 m² (approx. 270 sq.ft.)
- Main Bathroom (with vanity) – 4.6 m² (approx. 50 sq.ft.)

Note: This document is to be read in conjunction with the most current: “The Region of Peel Universal Accessibility Standards for Affordable Residential Properties” and “Crime Prevention Through Environmental Design” (CPTED) and/or any other document referenced in this document.

5.10.7 Four Bedrooms cont'd

- Powder Room (with basin) – 1.9 m² (approx. 20 sq.ft.)
- Entrance Foyer – 1.6 m² (approx. 17.2 sq.ft.)
- Closets/Storage (total no shelving) – 6.1 m² (approx. 66 sq.ft.)

* Includes all internal circulation within the unit.

5.10.8 Five Bedrooms

- Maximum NFA for the unit: 130 m² (1,400 sq.ft.)*
- Minimum NFA: 94.1 m² (1,013 sq.ft.), combined Living/Dining

As follows:

- Living Room – 18 m² (approx. 194 sq.ft.)
- Dining Room – 12 m² (approx. 130 sq.ft.),
- Kitchen (next to/with Living/Dining) – 11.2 m² (approx. 120 sq.ft.)
- Bedroom – 11.6 m² (approx. 125 sq.ft.)
- Bedroom (4 Additional) – totalling 33.5 m² (approx. 361 sq.ft.)
- Bathroom (2, with vanity) – totalling 9.2 m² (approx. 99 sq.ft.)
- Entrance Foyer – 1.6 m² (approx. 17.2 sq.ft.)
- Closets/Storage (total no shelving) – 7 m² (approx. 75 sq.ft.)

* Includes all internal circulation within the unit.

Note: This document is to be read in conjunction with the most current: “The Region of Peel Universal Accessibility Standards for Affordable Residential Properties” and “Crime Prevention Through Environmental Design” (CPTED) and/or any other document referenced in this document.

6.0 Submission Requirements and Format Standards



6.0 SUBMISSION REQUIREMENTS AND FORMAT STANDARDS

6.1 Warranties

- First year maintenance shall be included in the tender or modified turnkey.
- Any change to the required additional warranties will be at the Region of Peel's discretion.

Additional Warranties						
Division	Description	No. of Years	Division	Description	No. of Years	
Division 2 Site Work	- All pl	1	Division 8 Windows and Doors	- Wood doors (in suite)	1	
	- Seed/sod (1 year from date of planting)	1		- Steel hollow metal doors	2	
	- Repair of erosion/settlements	1		- Suite entry doors - Manufacturer	3	
	- Rodent control	5		- Suite entry doors - Contractor installation	1	
	- Paving	1		- Sectional overhead doors	2	
Division 3 Concrete	- Precast concrete panels	3		- Metal entrances and screens	1	
	- Structural	5	Division 9 Finishes	- Quarry, porcelain or ceramic tile	1	
Division 4 Masonry	- Masonry mortar and grout	3		- Wood flooring	1	
	- Masonry reinforcing and connectors	3		- Resilient tile or sheet flooring	5	
	- Brick masonry	3		- Carpeting - Manufacturer (in suite)	5	
	- Concrete unit masonry	3		- Carpeting - Manufacturer	10	
Division 5 Metals	- Structural steel	-		- Carpeting - Contractor installation	1	
Division 6 Wood and Plastics	- Carpentry finish (kitchen, washroom and laundry room millwork)	2		- Concrete floor sealants	2	
	- Plastic laminate (finishes)	2		- Parking garage topping	2	
Division 7 Thermal and Moisture Protection	- Fluid elastomeric waterproofing - Manufacturer	5		Division 10 Specialties	- Closet doors and shelves	1
	- Fluid elastomeric waterproofing - Contractor installation	2			- Toilet partitions	1
	- Chemical waterproofing - Manufacturer	5	- Mailboxes		1	
	- Chemical waterproofing - Contractor installation	2	Division 11 Equipment	- Garbage compactors, materials and workmanship	1	
	- Bituminous damp-proofing	3		- Garbage chute	1	
	- Board insulation	3	Division 14 Conveying System	- Elevators	1	
	- Built-up roofing	2		- Maintenance service Warranty - subject to sub-trade and the owner at the owner's expense entering into a two-year maintenance contract	2	
	- Protected membrane roofing - Manufacturer	5	Division 15 Mechanical	- Boiler heat exchanger (Manufacturer only)	5	
	- Protected membrane roofing - Contractor installation (traffic topping)	2	Division 16 Electrical	- Voice communication	1	
	- Flashing and sheet metal	2		- Emergency generator	2	
- Sheet metal roofing	2	- Fire alarm		2		
- Sealants and caulking	2	- Controls		2		

Note: This document is to be read in conjunction with the most current: "The Region of Peel Universal Accessibility Standards for Affordable Residential Properties" and "Crime Prevention Through Environmental Design" (CPTED) and/or any other document referenced in this document.

6.2 Drawings

6.2.1 Guidelines for Drawings

- The Region of Peel drawing standards will be provided to the proponent electronically via CD for copy purposes.
- The CD will include the following Region of Peel drawing standards:
 - Metric drawing templates (imperial drawing templates can be included) containing:
- Text standards and font styles
- Layer states
- Layers
- Line types
 - Metric (and imperial) title blocks: 279 x 431, 606 x 914, 914 x 1219
 - Plot style files (CTB files), and
 - Master layering list in Excel format (“Region of Peel Working Drawing Layer Standards.xls”).
- The proponent shall not deviate from the Region of Peel’s drawing standards

6.2.2 Drawing Submission Requirements

- All drawings shall state percent (%) completion for each review by the Region of Peel, 75, 95 and 100 percent.
- 75, 95 and 100 percent review drawing submission shall be 1,200 mm (4 ft.) x 900 mm (3 ft.) in size.
- All submitted electronic drawings must follow the master layering list provided (“Region of Peel Working Drawing Layer Standard.xls”) in order to be accepted into the Region of Peel environment.
 - Drawings that do not follow the Region of Peel’s drawing standards will not be accepted. Drawings will be returned to the vendor for correction and resubmission.
- Drawings submitted for project records are to be provided in PDF or TIF formats to protect professional stamps.
- “As Built” drawings are to be submitted to the owner’s representation (PM) by the consultant. They are to be submitted:
 - In AutoCAD 2010 “DWG” or a more current version format
 - On CD Rom
 - Within five weeks following the substantial completion of the project
 - Including all X-Reference drawings
 - Indicating a revision line(s) and date
 - Without protection
 - With professional stamps removed, for the use of the Region of Peel

Note: This document is to be read in conjunction with the most current: “The Region of Peel Universal Accessibility Standards for Affordable Residential Properties” and “Crime Prevention Through Environmental Design” (CPTED) and/or any other document referenced in this document.

6.3 Specifications

6.3.1 Guidelines for Construction Specifications

- Microsoft Word format, 2003 or later:
 - Letter size paper (8 ½" by 11")
 - PDF format is UNACCEPTABLE
- Formatting Instructions:
 - Font: Times New Roman
 - Font Size: 10 pt
 - Margins: L (1.25); R (1.25); T (1.0); B (1.0)
 - Paragraph: Justified Indentation at 0.5 intervals
- Numbering shall be as follows:

1. MAIN HEADING

1.1. Sub-Heading

- Type to indent ½" from number

6.3.2 Construction Specifications

- Shall conform to the most recent version of the CSC and CSI Uniform "MasterFormat," either 16 Divisions or 49 Divisions standards – Master list of sections, titles and numbers.
- Consultant's company name and/or logo to be excluded from the specifications' headers and footers.
- Other attachments or appendices to be compatible with the aforementioned formatting instructions.

6.3.3 Submission Requirements

- Specifications to be submitted to the Region's PM via e-mail or CD Rom.
- All specifications must state percent completion for each review by the Region of Peel, 75, 95 and 100 percent.

6.4 Marketing

- 1, 2, 3 bedrooms and barrier-free mock-up unit are to be made available for rent-up once the building reaches 75 percent completion. This area shall have partial occupancy and be free of any construction material.
- Architect shall provide rent-up marketing package to the owner as per MTKA requirements and schedule.
- The marketing package shall include:
 - Layout of each type of unit, simplified floor plans and parking garage plans.
 - Layouts shall list unit type, unit number, typical unit size and room names.
 - Floor layouts shall state all public areas, amenities and service rooms. Underground parking layout shall include numbers for parking spaces, clear identification of levels and barrier-free spaces.

Note: This document is to be read in conjunction with the most current: "The Region of Peel Universal Accessibility Standards for Affordable Residential Properties" and "Crime Prevention Through Environmental Design" (CPTED) and/or any other document referenced in this document.

6.4 Marketing cont'd

- Site plan layout shall provide information about access parking and location of site.
- Provide a colour rendering of the project.
- Typical layout of units on 8 ½" by 11" paper.
- All marketing presentations and conceptual packages must be reviewed by the Region of Peel prior to preparation.

Note: This document is to be read in conjunction with the most current: "The Region of Peel Universal Accessibility Standards for Affordable Residential Properties" and "Crime Prevention Through Environmental Design" (CPTED) and/or any other document referenced in this document.

Appendix A

Finishes Schedule



FINISHES SCHEDULE

Interior Finishes Schedule (Building)

Rooms	Floor	Base	Wall	Ceiling	Notes
Building Entrance Vestibule	Quarry or porcelain tile (slip-resistant finish)	Quarry or porcelain tile	Drywall-painted where applicable	Drywall-painted (no texture) OR Acoustic tile with prefinished t-bar and clips	Glazed aluminum wall sections are preferred to provide good visibility and natural light in the building.
Building Entrance Lobby	Quarry tile with architectural border	Quarry or porcelain tile	Vinyl wall covered with wainscoting details and chair rail	Drywall-painted (no texture) OR Acoustic tile with prefinished t-bar. Provide a coffered ceiling feature with recessed lighting.	Provide a feature wall as per Section 5.8.1.
Elevator Lobbies	Quarry or porcelain tile (slip-resistant finish)	Quarry or porcelain tile	Vinyl wall covered with wainscoting details and chair rail	Drywall-painted (no texture)	Flooring to be of a contrasting colour from public corridors.
Public Corridors	Carpet tiles are to be 28 oz. nylon pattern, 500 mm x 500 mm (19.7 in. x 19.7 in.), stain-protected, tufted cut and looped	100 mm (4 in.) hardwood clear or stained	Drywall-painted with wainscoting		Provide abuse/impact-resistant drywall on walls up to 1,200 mm (4 ft.) AFF. Provide corner guards at all exposed corners and handrails on one side.
Exit Stairs	Concrete, epoxy painted (grey)	Epoxy painted, 100 mm (4 in.) base (grey to match floor)	Concrete, epoxy painted (off-white)	Concrete, epoxy painted (off-white)	Painted/powder-coated metal handrails and railings (black).
Region of Peel Office	Quarry or porcelain tile	Quarry or porcelain tile	Drywall-painted	Drywall-painted (no texture)	Side tile at entry door to be a minimum of 600 mm (2 ft.) wide.
Activity/Multi-purpose (Lounge, Recreation)	Commercial-duty vinyl flooring (wood grain pattern), such as AMITCO LUXURY 500 or equivalent	100 mm (4 in.) wood to match floor colour	Drywall-painted with selective vinyl wall covering. Provide wainscoting and chair rails.	Acoustic tile with pre-finished t-bar and clips	All paint shall be washable. Consider engineered or wood laminate flooring as an alternative.

Note: This document is to be read in conjunction with the most current: “The Region of Peel Universal Accessibility Standards for Affordable Residential Properties” and “Crime Prevention Through Environmental Design” (CPTED) and/or any other document referenced in this document.

Interior Finishes Schedule (Building)

Rooms	Floor	Base	Wall	Ceiling	Notes
Mail	Quarry or porcelain tile	Quarry or porcelain tile	Drywall-painted	Drywall-painted (no texture) OR Acoustic tile with prefinished t-bar	All paint shall be washable.
Moving	Concrete, epoxy painted (grey)	Epoxy coat to continue 150 mm (6 in.) up all perimeter surfaces/walls (grey)	Concrete, epoxy painted (off-white)	Drywall-painted (no texture) OR concrete/ block structure-painted (off-white)	Exposed surfaces must be jacketed (PVC) and painted. Provide wall bumper for containers and stainless steel corner guards at 1,800 mm (6 ft.) AFF on all outside corners.
Central Storage	Concrete, epoxy painted (grey)	Epoxy coat to continue 150 mm (6 in.) up all perimeter surfaces/walls (grey)	Concrete, epoxy painted (off-white)	Drywall-painted (no texture) OR concrete/ block structure-painted (off-white)	Exposed surfaces must be jacketed (PVC) and painted. Provide wall bumper for containers and stainless steel corner guards at 1,800 mm (6 ft.) AFF on all outside corners.
Bicycle Storage	Concrete, epoxy painted (grey)	Epoxy coat to continue 150 mm (6 in.) up all perimeter surfaces/walls (grey)	Concrete, epoxy painted (off-white)	Drywall-painted (no texture) OR concrete/ block structure-painted (off-white)	Exposed surfaces must be jacketed (PVC) and painted. Provide wall bumper for containers and stainless steel corner guards at 1,800 mm (6 ft.) AFF on all outside corners.
Garbage Chute	100% vinyl sheet flooring with welded seams	Ceramic tile dado a minimum of 300 mm (1 ft.) above the top of the chute door	Drywall-painted above dado	Drywall-painted (no texture)	All paint shall be washable.
Public Washrooms	457 mm x 457 mm (18 in. x 18 in.) non-slip quarry or porcelain tile	150 mm (6 in.) quarry or porcelain tile to match floor	Cement board and ceramic tile up to a minimum 1,200 mm (4 ft.) dado on all walls	Moisture-resistant drywall ceiling, painted with washable paint	
Underground Parking Garage	Concrete with top wear surface (black). Spaces to be marked and numbered.	Bottom of wall to have painted 600 mm (2 ft.) strip (black)	Painted concrete (white). Columns to be moisture-resistant, painted-drywall (white) with 600 mm (2 ft.) painted base colour coded for each level.	Painted concrete (white)	Provide protection and jacketing to all exposed services. Exits and lobby areas to be clearly identified/colour coded for each level. Provide a low-odour polyurethane deck coating system for vehicular traffic such as BASF CONIPUR PLUS or equivalent.

Note: This document is to be read in conjunction with the most current: "The Region of Peel Universal Accessibility Standards for Affordable Residential Properties" and "Crime Prevention Through Environmental Design" (CPTED) and/or any other document referenced in this document.

Interior Finishes Schedule (Building)

Rooms	Floor	Base	Wall	Ceiling	Notes
Garbage/ Compactor	Quarry or porcelain tile	Epoxy coat to continue 150 mm (6 in.) up all perimeter surfaces (grey). Floor and wall joint to be sealed with silicone.	Concrete and/or block, epoxy painted (off-white)	Concrete structure-painted (off-white)	Exposed surfaces must be jacketed (PVC) and painted. Provide wall bumper for containers and stainless steel corner guards at 1,800 mm (6 ft.) AFF on all outside corners. Provide hot and cold water supply and floor drain(s).
Recycling	Concrete, epoxy painted (grey)	Epoxy coat to continue 150 mm (6 in.) up all perimeter surfaces (grey)	Concrete and/or block, epoxy painted (off-white)	Concrete structure-painted (off-white)	Exposed surfaces must be jacketed (PVC) and painted. Provide wall bumper for containers and stainless steel corner guards at 1,800 mm (6 ft.) AFF on all outside corners.
Janitor's Closet (Housekeeping)	Concrete, epoxy painted (grey)	100 mm (4 in.) ceramic to match floor	Painted AND ceramic tile to 1,200 mm (4 ft.) AFF	Moisture-resistant, drywall-painted	All paint shall be washable. Curbed floor drain area comes with hot/cold water supply. A minimum of four Janitor's Closets shall be provided throughout the building as per Section 5.9.5.8.
Electrical Closet (Telephone, IT, Cable Closets)	Concrete, epoxy painted (grey)	Epoxy coat to continue 150 mm (6 in.) up all perimeter surfaces (grey)	Concrete, epoxy painted (off-white)	Concrete structure-painted (off-white)	Provide wall and outside corner protection.
CACF	Quarry or porcelain tile	100 mm (4 in.) quarry or porcelain tile to match floor	Painted-drywall	Acoustic tile with prefinished t-bar and clips	Provide structural backing for equipment.
Transformer Vault (as required)	Concrete, epoxy painted (grey)	Epoxy coat to continue 150 mm (6 in.) up all perimeter surfaces (grey)	Concrete and/or block, epoxy painted (off-white)	Concrete structure-painted (off-white)	Provide wall and outside corner protection.
Mechanical, Electrical	Concrete, epoxy painted (grey)	Epoxy coat to continue 150 mm (6 in.) up all perimeter surfaces (grey)	Concrete and/or block, epoxy painted (off-white)	Concrete structure-painted (off-white)	Provide wall and outside corner protection.
Emergency Generator	Concrete, epoxy painted (grey)	Epoxy coat to continue 150 mm (6 in.) up all perimeter surfaces (grey)	Concrete and/or block, epoxy painted (off-white)	Concrete structure-painted (off-white)	Provide wall and outside corner protection.
Workshop	Concrete, epoxy painted (grey)	Epoxy coat to continue 150 mm (6 in.) up all perimeter surfaces (grey)	Concrete and/or block, epoxy painted (off-white)	Concrete structure-painted (off-white)	Provide wall and outside corner protection.
Laundry	Quarry or porcelain tile, non-slip, minimum 457 mm x 457 mm (18 in. x 18 in.)	100 mm (4 in.) quarry or porcelain tile to match floor	Cement board with ceramic tile dado around washers, dryers and backsplash for sink at a height of 1,200 mm (4 ft.)	Drywall-painted (no texture)	All paint shall be washable. All corners to be finished with corner beads. Drywall corners to be protected with corner guards.

Note: This document is to be read in conjunction with the most current: "The Region of Peel Universal Accessibility Standards for Affordable Residential Properties" and "Crime Prevention Through Environmental Design" (CPTED) and/or any other document referenced in this document.

Interior Finishes Schedule (Unit/Suite)					
Rooms	Floor	Base	Wall	Ceiling	Notes
Recessed Suite Entry	Accent carpet tile to highlight entrances	100 mm (4 in.) hardwood, clear or stained	Drywall-painted with wainscoting	Drywall-painted with recessed lighting as per Section 5.8.2	Provide abuse/impact-resistant drywall on walls up to 1,200 mm (4 ft.) AFF. Recess to be a minimum of 300 mm (1 ft.) as per Section 5.8.2.
Entry Foyer	100% vinyl tile	A combination 125 mm (5 in.) high and 12.5 mm (1/2 in.) profile wood base with a quarter round trim, painted	Drywall-painted	Textured and painted	All paint shall be washable. Install a clear silicone bead between floor baseboard and floor.
Living Room/ Dining Room and Bedrooms	100% vinyl tile	A combination 125 mm (5 in.) high and 12.5 mm (1/2 in.) profile wood base with a quarter round trim, painted	Drywall-painted	Textured and painted	All paint shall be washable. Install a clear silicone bead between floor baseboard and floor.
Kitchen	Concrete, epoxy painted (grey)	A combination 125 mm (5 in.) high and 12.5 mm (1/2 in.) profile wood base with a quarter round trim, painted	Drywall-painted	Smooth surface-painted (no texture)	Provide ceramic tile backsplash between counter and upper cabinets. At stove location, continue backsplash down to floor level.
Bathroom(s)	100% vinyl tile, 457 mm x 457 mm (18 in. x 18 in.) such as AMTICO LUXURY 500 or equivalent	A combination 125 mm (5 in.) high and 12.5 mm (1/2 in.) profile wood base with a quarter round trim, painted	Wall tile in tub area where required. Provide 1,200 mm (4 ft.) ceramic tile dado. Drywall painted above dado.	Drywall-painted (no texture)	All drywall to be water and mildew-resistant. All paint shall be washable. All corners to be finished with tile accessories NOT sealant.
Closets and Walk-in Closets	100% vinyl tile	A combination 125 mm (5 in.) high and 12.5 mm (1/2 in.) profile wood base with a quarter round trim, painted	Drywall-painted	Drywall-painted	All paint shall be washable. Closet doors shall be swing type.
Storage Room	100% vinyl tile	A combination 125 mm (5 in.) high and 12.5 mm (1/2 in.) profile wood base with a quarter round trim, painted	Drywall-painted	Drywall-painted	All paint shall be washable.
Hallway(s)	100% vinyl tile	A combination 125 mm (5 in.) high and 12.5 mm (1/2 in.) profile wood base with a quarter round trim, painted	Drywall-painted	Textured and painted	All paint shall be washable.

General Notes: Perform paint work to Master Painters' and Decorators' Association (MPDA) requirements for premium grade. Material colours/patterns will be selected at a later date by the architect and approved by the owner. Allow for colour selection beyond manufacturer's standard colour range. All trim to be finished with a glossy paint except where noted. Use Benjamin Moore paint – Aura semi-gloss waterborne interior paint or equivalent as approved by the owner. Floors to meet IIC rating as per OBC requirements. No pine allowed. Grout colour to be selected by the owner/Region of Peel.

Note: This document is to be read in conjunction with the most current: "The Region of Peel Universal Accessibility Standards for Affordable Residential Properties" and "Crime Prevention Through Environmental Design" (CPTED) and/or any other document referenced in this document.

Appendix B

Millwork Schedule



MILLWORK SCHEDULE

1.0 General

- 1.1** The work described herein includes the supply of all labour, materials, tools and equipment necessary to perform the work as detailed within this document.
- 1.2** The prime work under this contract is for the production of all kitchen, bathroom and laundry room cabinets and countertops.

2.0 Kitchen

The proponent shall:

- 2.1** Create finished multiple cabinet sections to be combined together on site to create upper and lower kitchen cabinets.
- 2.2** Supply base and upper cabinets with overall dimensions determined from shop drawings and confirmed by field measurements by vendor staff to verify size and necessary filler strips.
- 2.3** Construct the cabinet box of Formica laminate, or equivalent, on a 16 mm (11/16 in.) particle board for all cabinets except the sink cabinet floor.
- 2.4** Construct the sink cabinet floor of Formica laminate, or equivalent, on 16 mm (11/16 in.) plywood. The three edges of the cabinet floor shall be caulked with kitchen/bathroom-grade clear silicone.
- 2.5** Construct door to be a five piece, Shaker Style, constructed with hardwood maple frame, with 6 mm (1/4 in.) maple veneer plywood panel infill and a clear finish.
- 2.6** Provide door hinges with a 110 degree minimum opening and with a European style metal construction.
- 2.7** Construct drawer front to be a five-piece, Shaker Style, constructed with hardwood maple frame, with 6 mm (1/4 in.) maple veneer plywood panel infill and a clear finish.
- 2.8** Construct drawer body of a formed metal pan with nylon wheel roller glides.
- 2.9** Provide drawers with a “soft close” anti-slam feature.
- 2.10** Provide door and drawer pulls with 128 mm (5 in.) “D” shape brushed nickel metal handle, installed on the upper face of hardwood maple front.
- 2.11** Provide countertops with a bull nose post-form front edge.
- 2.12** Supply a Wessan 530 mm x 810 mm (21 in. x 32 in.) double bowl, 20 gauge stainless steel sink with a 3-hole ledge back, 100 mm (4 in.) centre, and with a fine brushed satin finish deck and bowl, or equivalent.
- 2.13** Supply a Moen “Chateau” one-handle lever kitchen faucet, chrome finish, ADA compliant, 100 mm (4 in.) centre set design, or equivalent.

Note: This document is to be read in conjunction with the most current: “The Region of Peel Universal Accessibility Standards for Affordable Residential Properties” and “Crime Prevention Through Environmental Design” (CPTED) and/or any other document referenced in this document.

3.0 Bathroom

The proponent shall:

- 3.1** Create finished sink cabinet for washroom vanity.
- 3.2** Supply a Crane “Canada” 483 mm (19 in.) round basin, with a 3-hole ledge back, 100 mm (4 in.) centre, long-lasting porcelain enamelled steel, self rimming round countertop with built-in soap depression, concealed front overflow and white colour, or equivalent.
- 3.3** Supply a Moen “Chateau” one-handle lever faucet, chrome finish, ADA compliant, 100 mm (4 in.) centre-set design with a pop-up drain, or equivalent.

4.0 Laundry Room

The proponent shall:

- 4.1** Supply a Wessan 530 mm x 610 mm (21 in. x 24 in.) single bowl, 310 mm (12 1/8 in.) deep, 18 gauge stainless steel sink with a 3-hole ledge back, 100 mm (4 in.) centre with a fine brushed satin finish deck and bowl, or equivalent.
- 4.2** Supply a Moen “Chateau” one-handle lever faucet, chrome finish, ADA compliant, 100 mm (4 in.) centre set design, or equivalent.

Note: This document is to be read in conjunction with the most current: “The Region of Peel Universal Accessibility Standards for Affordable Residential Properties” and “Crime Prevention Through Environmental Design” (CPTED) and/or any other document referenced in this document.

Appendix C

Region of Peel Universal Accessibility Standards for Affordable Residential Properties

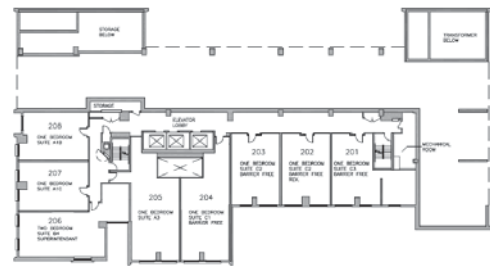

1.0 Access and Circulation

1.1 Space Requirements.....	62
1.2 Ground and Floor Surfaces	62
1.3 Accessibility Routes	63
1.4 Accessible Doors	63
1.5 Windows, Glazed Screens and Sidelights	65
1.6 Ramps.....	65
1.7 Stairs.....	66
1.8 Handrails.....	66
1.9 Elevators.....	67

2.0 Washroom Facilities

2.1 Toilets.....	68
2.2 Lavatories/Hand Basins.....	69
2.3 Washroom Accessories in Common Area Washrooms.....	69
2.4 Individual/Family Washrooms.....	69
2.5 Bathtubs.....	70
2.6 Shower Stalls in Barrier-free Suites	70
2.7 Grab Bars	71

3.0 Other Amenities

3.1 Tables, Counters, Work Surfaces	71
3.2 Information, Reception, Service Counters and Mailboxes	72
3.3 Storage and Shelving.....	73
3.4 Parking	73
3.5 Passenger Loading Zones	74

4.0 Systems and Controls

4.1 Areas of Rescue.....	74
4.2 Controls and Operating Mechanics.....	75
4.3 Visual Alarms.....	75
4.4 Signage	76
4.5 Detectable Warning Surfaces	78
4.6 Card Access.....	79
4.7 Glare and Light Sources.....	79
4.8 Lighting.....	80
4.9 Materials and Finishes	81
4.10 Texture and Colour.....	81
4.11 Heating, Cooling and Ventilation Systems (HVAC)	82
4.12 Acoustics.....	82

Table of Contents



5.0 Kitchens

5.1 Kitchen Requirements.....	83
-------------------------------	----

6.0 Maintenance

6.1 Housekeeping Considerations.....	84
--------------------------------------	----

Criteria

1. These standards only apply to Region of Peel affordable housing projects.
2. The Accessibility Standards shall be reviewed and applied using the following criteria: affordability, functionality and operability.
3. The cost factor has not been evaluated and may rule out certain proposed standards.
4. These standards are to be used in conjunction with the Region of Peel Affordable Housing Guidelines.
5. These standards are preliminary and evolving.
6. These standards are to be reviewed and refined after their application to real-life projects.
7. Where a range is provided for dimensions, it is preferable to use the maximum figure; however, depending on budget limitations, the lower figure would be the acceptable minimum.



Table of Contents

REGION OF PEEL ACCESSIBILITY STANDARDS FOR AFFORDABLE RESIDENTIAL PROPERTIES

1.0 Access and Circulation

1.1 Space Requirements

- 1.1.1** Suite layouts to be more open concept by having as few walls as possible.
- 1.1.2** As illustrated in Figure 1, the wheelchair turning radius is to be 1,500 mm (5 ft.) to 2,440 mm (8 ft.) with 2,440 mm provided in building common areas such as lobbies and recreation areas.
- 1.1.3** As illustrated in Figure 2, clear floor space to accommodate a wheelchair is to be 760 mm x 1,220 mm (2.5 ft. x 4 ft.). Where design permits, use 900 mm x 1,300 mm (3 ft. x 4.25 ft.).
- 1.1.4** Wheelchair clear space heights must be at least:
- Toe = 230 mm to 450 mm (0.75 to 1.5 ft.)
 - Seat = 480 mm (1.6 ft.)
 - Lap = 675 mm to 685 mm (2.2 ft. to 2.25 ft.)
 - Arm rest = 760 mm (2.5 ft.)
- 1.1.5** Avoid any instances of protruding objects within a path of travel, where possible. Where a protrusion cannot be avoided, as see in Figure 3, it shall not protrude more than 100 mm (4 in.) from the wall. If an object protrudes more than 100 mm (4 in.), it shall be marked with a cane-detectable guide-rail if the leading edge of the object is between 685 mm to 2.03 m (27 in. to 6 ft. 8 in.) above grade.

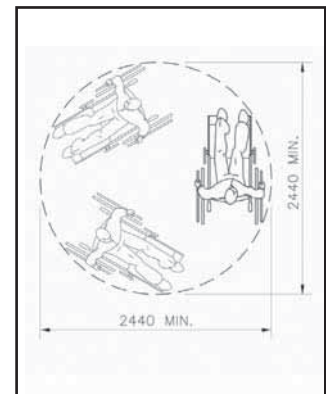

Figure 1

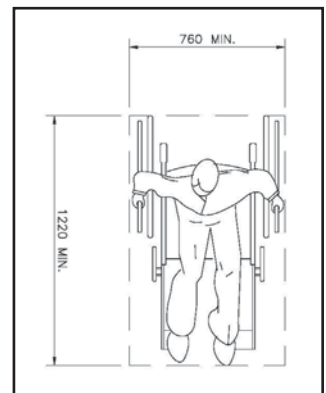

Figure 2

1.2 Ground and Floor Surfaces

- 1.2.1** Ground and floor surfaces shall be stable, firm, slip-resistant, glare-free and not heavily patterned.
- 1.2.2** Carpets or carpet tile shall:
- Be securely fixed (i.e. commercial carpet without padding adhered to the floor),
 - Have a level loop, textured loop, level cut pile, or level cut/uncut pile texture with a maximum pad and pile height of 13 mm; and
 - Have exposed edges fastened to floor surfaces
 - The smell of new carpets can adversely affect people with environmental sensitivity. The use of carpets that have been off gassed prior to installation is required.

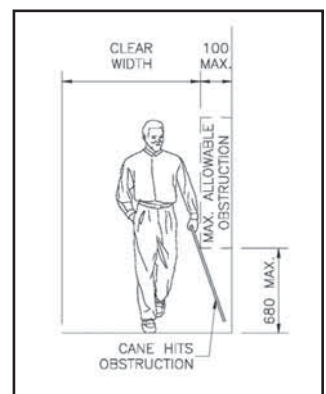

Figure 3

Note: This document is to be read in conjunction with the most current: “The Region of Peel Universal Accessibility Standards for Affordable Residential Properties” and “Crime Prevention Through Environmental Design” (CPTED) and/or any other document referenced in this document.

1.2 Ground and Floor Surfaces cont'd

- 1.2.3 Residential in-suite corridors shall be a minimum of 1,100 mm wide (3.6 ft.)
- 1.2.4 Common area corridors require a suitable and colour-contrasted handrail on both sides of the corridor.

1.3 Accessibility Routes

- 1.3.1 Provide a clear width of 1,500 mm (5 ft.).
- 1.3.2 Provide a clear width of 850 mm to 950 mm (2.8 ft. to 3 ft.) at doors. To facilitate access in a hallway, doors are to be aligned so that they are across from each other.
- 1.3.3 The slope of accessible routes must be less than or equal to 1:20. The maximum slope of 1:20 will prevent the necessity of ramps where slopes are still fairly low.
- 1.3.4 The cross slope is not to be steeper than 1:50.

1.4 Accessible Doors

- 1.4.1 All principal building entrances, not designated as exits, are to be accessible and have two sets of sliding doors. Other accessible doors are to have auto door openers.
- 1.4.2 Operators shall be 150 mm wide. The controls for button-operated out-swinging doors shall be mounted outside and in front of the door swing, to avoid the situation where an individual using a mobility aid is required to back-up to allow the door to open. This may be achieved in several ways, including wall-mounting or post-mounting the controls.
- 1.4.3 Where there are two sets of sliding doors, the layout of light beam coverage shall ensure that persons using mobility aids (e.g. wheelchairs/scooters), seniors or persons with visual limitations have time to clear the opening safely, before the door closes again. A security card swipe shall be installed at the inner set of sliding doors.
- 1.4.4 Notwithstanding sliding doors, hardware on interior building doors shall include levers (for suite doors) or D-shaped pulls (on exterior doors). Levers shall be 75 mm to 100 mm long. See Figure 4 for illustrated example.
- 1.4.5 Thresholds are to be no more than 13 mm high and shall be gently bevelled.
- 1.4.6 Sweep period of door closers must be at least 3 seconds to move from an open 90 degree position to a semi-closed position of approximately 12 degrees. Closers shall be adjusted to the least pressure possible, but never more than the opening forces.
- 1.4.7 Where exterior doors swing open into a pedestrian area, they shall incorporate safety guards and project beyond both sides of the open door by a minimum of 300 mm to 305 mm. See Figure 5 for illustrated example.

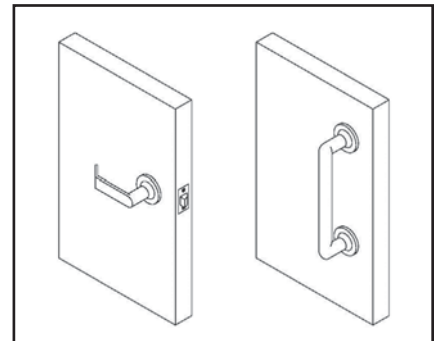

Figure 4

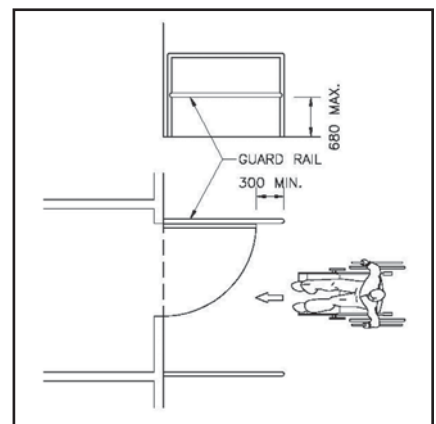

Figure 5

Note: This document is to be read in conjunction with the most current: “The Region of Peel Universal Accessibility Standards for Affordable Residential Properties” and “Crime Prevention Through Environmental Design” (CPTED) and/or any other document referenced in this document.

1.4 Accessible Doors cont'd

1.4.8 For hinged side approach at hinged doors without automatic operators – wheelchair users are to go passed the door and re-approach at latch side. See item 1.4.9.

1.4.9 Latch-side approach at hinged doors without automatic operators – required dimensions are illustrated in Figure 6.

1.4.10 For front-side approach at hinged doors without automatic operators – dimensions are illustrated in Figure 7.

1.4.11 For front and side approach at sliding doors – dimensions are illustrated in Figure 8.

1.4.12 For maneuvering space at doors without automatic operators in series (parallel to each other) – dimensions are illustrated in Figure 9.

1.4.13 For maneuvering space at doors without automatic operators in series (90 degrees to each other) – dimensions are illustrated Figure 10.

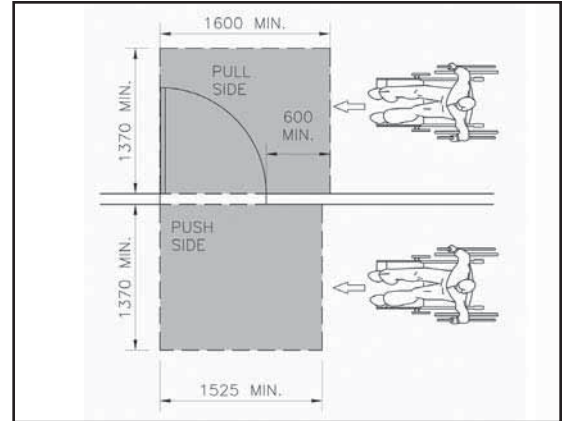

Figure 6

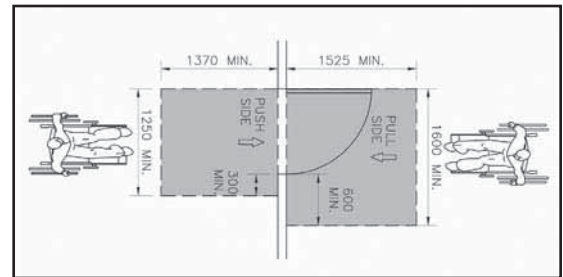

Figure 7

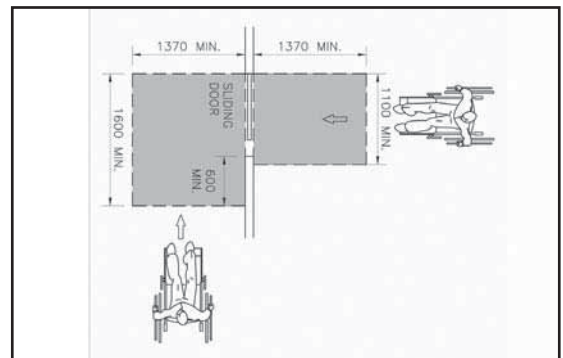

Figure 8

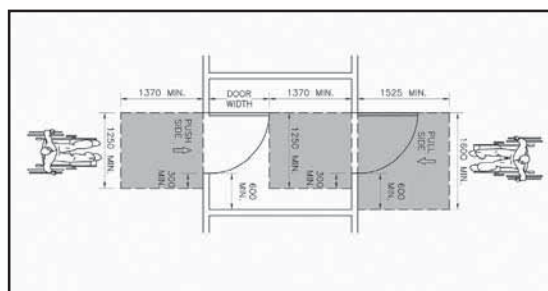

Figure 9

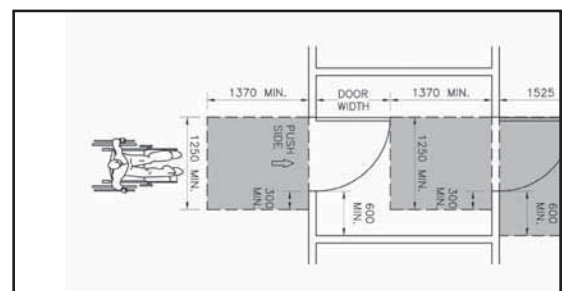

Figure 10

Note: This document is to be read in conjunction with the most current: “The Region of Peel Universal Accessibility Standards for Affordable Residential Properties” and “Crime Prevention Through Environmental Design” (CPTED) and/or any other document referenced in this document.

1.5 Windows, Glazed Screens, and Sidelights

- 1.5.1** Maximum allowable sill height is 760 mm (2.5 ft.).
- 1.5.2** Transoms are not to be located between 1,060 mm and 1,220 mm (3.5 ft. to 4 ft.).
- 1.5.3** Window controls must be mounted between 400 mm and 1,200 mm (1.3 ft. to 3.9 ft.).
- 1.5.4** Fully glazed sidelights at entrances and vestibules, as well as fully glazed interior screens, shall be clearly identified with a horizontal row of decals or continuous stripe at least 50 mm in width.
- 1.5.5** Frameless glass doors and/or sidelights shall not be used.
- 1.5.6** Partially glazed doors shall have glazed panels that extend low enough (900 mm or 3 ft. max. to bottom edge) to allow persons with mobility aids to see what is on the far side of the door.

1.6 Ramps

- 1.6.1** Every effort shall be made to have level floors rather than incorporate interior ramps. However, where it is not possible, interior ramps would be better than having stairs.
- 1.6.2** Slope of ramp to be between 1:12 to 1:25.
- 1.6.3** Maximum allowable cross slope is 1:50.
- 1.6.4** Required ramp width is between 1,100 mm and 1,525 mm (3.6 ft. to 5 ft.).
- 1.6.5** Have landings at the top and bottom of each run and at changes in direction and at every 9 m (29.5 ft.) as illustrated in Figure 11.
- 1.6.6** Minimum required floor clearance at top or bottom of ramp is 2,440 mm x 2,440 mm (8 ft. x 8 ft.).
- 1.6.7** No door shall open onto ramp.
- 1.6.8** Handrails are required on both sides of ramps and shall extend beyond the head and foot of the ramp by 300 mm (1 ft.).
- 1.6.9** Handrails are to be continuous on the inside of switchback (U-shaped) or dogleg (L-shaped) ramps.
- 1.6.10** Two sets of handrails are required.
- 1.6.11** Required height of the upper handrail from ramp surface is 865 mm to 965 mm (2.8 ft. to 3.2 ft.).
- 1.6.12** Required height of the lower handrail is 600 mm to 700 mm (2 ft. to 2.3 ft.).
- 1.6.13** Required clearance of the handrail from the wall is 50 mm to 60 mm, taking into account winter gloves.

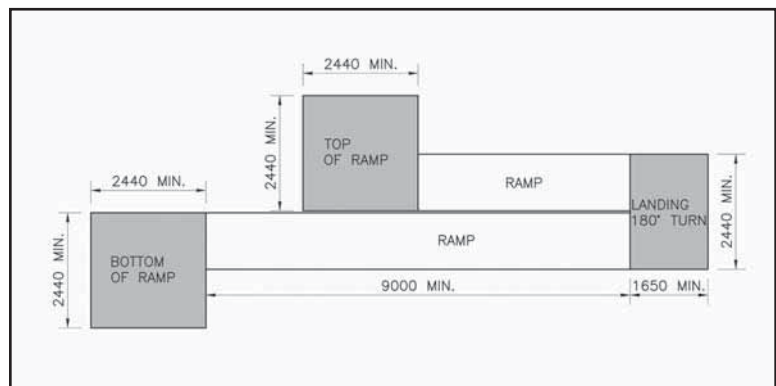

Figure 11

Note: This document is to be read in conjunction with the most current: "The Region of Peel Universal Accessibility Standards for Affordable Residential Properties" and "Crime Prevention Through Environmental Design" (CPTED) and/or any other document referenced in this document.

1.7 Stairs

- 1.7.1** A flight of stairs shall have uniform riser heights and tread depths. Width must be 1 m (3.3 ft.) wide and unobstructed.
- 1.7.2** There shall be a minimum of 1,200 mm of flight between landings (4 ft.).
- 1.7.3** Riser height shall be between 180 mm and 200 mm (7 in. to 8 in.) as illustrated in Figure 12.
- 1.7.4** Run is to be no less than 280 mm and no more than 355 mm deep, measured from riser to riser (11 in. to 14 in.) for new construction and preferred application for reconstruction as illustrated in Figure 12.
- 1.7.5** An open riser with nosing presents a tripping hazard and shall be avoided. Stairs with open risers are hazardous to individuals who need a solid riser to guide the foot up or who place crutches or canes against the riser of the next step.
- 1.7.6** Nosings shall not project more than 25 mm, have no abrupt undersides and have a curved or bevelled leading edge of the tread between 6 mm to 13 mm.
- 1.7.7** Handrails are to be installed on both sides of the stairs if there are 3 or more steps. Also steps or stairs that are 2.2 m (7 ft. 2 in.) or greater in width shall include an intermediate (middle) handrail to assist individuals with limited mobility or low vision.
- 1.7.8** Handrails are to be uniform in height between 800 mm to 920 mm (2.6 ft. to 3 ft.) from stair nosing.
- 1.7.9** Handrails are to extend horizontally at the top and bottom of the stairs not less than 300 mm, at a height ranging between 865 mm and 920 mm above the floor; and for the bottom, extend 300 mm plus one tread depth.

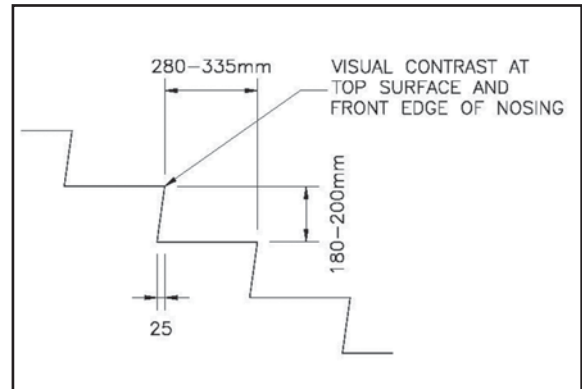

Figure 12

1.8 Handrails

- 1.8.1** Must have a circular section 30 mm to 45 mm in diameter or any non-circular shape, with a graspable portion that has a perimeter no less than 100 mm and no more than 155 mm whose largest cross-sectional dimension is not more than 57 mm. Refer to Figure 13.
- 1.8.2** Must be free of sharp elements.
- 1.8.3** Have continuous gripping surfaces without interruption by newel posts, other construction elements, or obstructions that can break a handhold.
- 1.8.4** Have a clear space between the handrail and the wall between 50 mm to 60 mm. Refer to Figure 13.
- 1.8.5** Be terminated in a manner that will not obstruct pedestrian travel or create a hazard.

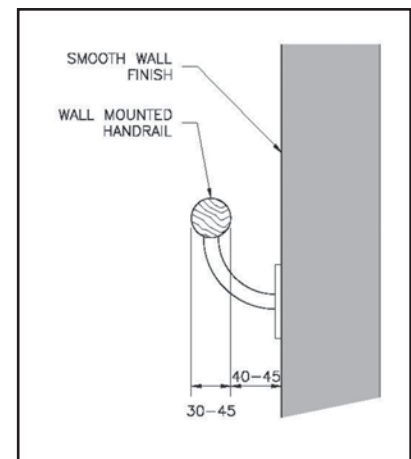

Figure 13

Note: This document is to be read in conjunction with the most current: “The Region of Peel Universal Accessibility Standards for Affordable Residential Properties” and “Crime Prevention Through Environmental Design” (CPTED) and/or any other document referenced in this document.

1.9 Elevators

- 1.9.1** Elevators shall comply with the most recent CSA Standards CAN/CSA-B44 “Safety Code for Elevators” and CAN/CSA-B355 “Lifts for Persons with Physical Disabilities”.
- 1.9.2** Shall be automatic and be provided with a 2-way automatic maintaining levelling device to maintain the floor level to +/- 13 mm when the doors open.
- 1.9.3** Power-operated horizontal sliding car and landing doors to be opened and closed by automatic means.
- 1.9.4** Doors shall be provided with a door re-opening device that will function to stop and re-open a car door and an adjacent hoist way door to at least 950 mm, in case the car door is obstructed while closing. This re-opening device shall also be capable of sensing an object or person in the path of a closing door at a nominal 125 ± 25 mm and 735 ± 25 mm above the floor without requiring contact for activation.
- 1.9.5** Required clear width of elevator doors is 915 mm to 950 mm (~3 ft.). Refer to Figure 14.
- 1.9.6** The elevator shaft shall be designed to accommodate two sets of doors (front and back), notwithstanding space limitations, so that users can exit without having to turn around.
- 1.9.7** The minimum distance between the walls or between wall and door, excluding return panels, shall be no less than 1,725 mm x 1,500 mm. At least one elevator shall be 1,725 mm x 2,285 mm to accommodate a stretcher.
- 1.9.8** Floor register buttons in elevator cabs shall be a minimum 19 mm and may be raised, flush or recessed. The depth of flush or recessed buttons when they are being operated shall not exceed 10 mm; and be provided with visual and momentary audible indicators to show when each call is registered. The visual indicators shall be extinguished when each call is answered. Refer to Figure 17.
- 1.9.9** All car control buttons shall be designated by Grade 2 Braille characters and by raised standard alphabet characters for letters, Arabic characters for numbers, and standard symbols. Markings shall be a minimum of 16 mm high and raised a minimum of 0.75 mm, placed immediately to the left of the buttons to which they apply. Exception: Where the call buttons are mechanical, the raised markings may be on the buttons. Refer to Figure 17.

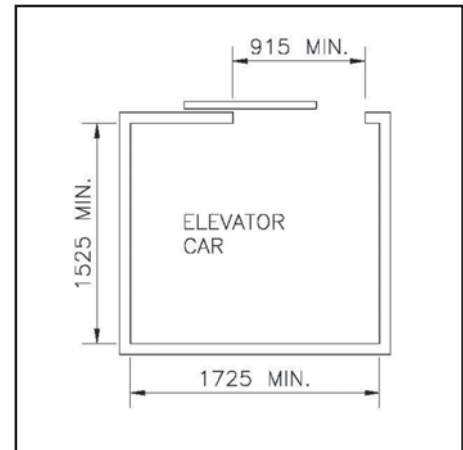

Figure 14

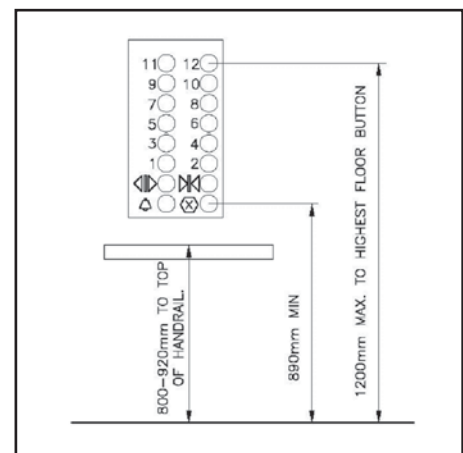

Figure 15

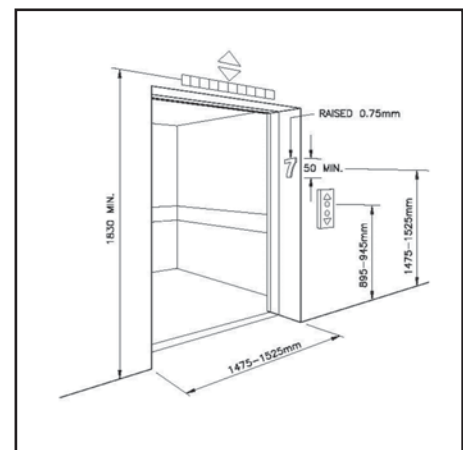

Figure 16

Note: This document is to be read in conjunction with the most current: “The Region of Peel Universal Accessibility Standards for Affordable Residential Properties” and “Crime Prevention Through Environmental Design” (CPTED) and/or any other document referenced in this document.

1.9 Elevators cont'd

- 1.9.10** Emergency car controls and door operating buttons shall be grouped together at the bottom of the control panel. The centre line of the alarm button and the emergency stop switch shall be not less than 890 mm to 920 mm high (~3 ft.). Refer to Figures 15 and 17.
- 1.9.11** The centre line of the highest floor button shall be no higher than 1,200 mm (~4 ft.). Refer to Figure 15.
- 1.9.12** The centre line of hall call buttons above the floor shall be 895 mm to 945 mm (~3 ft.). Refer to Figure 16.
- 1.9.13** All elevator hoist way entrances shall have raised Arabic numerals and Braille floor designations provided on both jambs. The characters shall be raised at least 0.75 mm and be a minimum height of 50 mm. Refer to Figure 16.

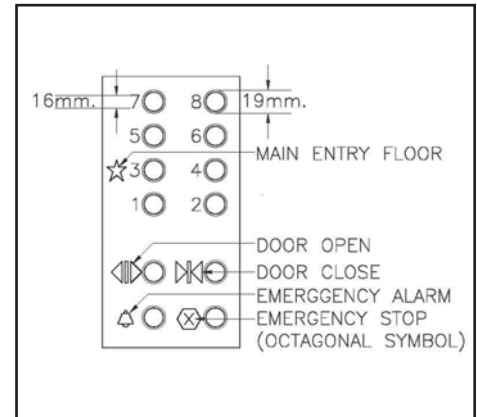

Figure 17

2.0 Washroom Facilities

2.1 Toilets

- 2.1.1** Spring-activated seats are not allowed; must provide back support if there is no seat lid or tank; tank top must be securely attached. Refer to Figure 18.
- 2.1.2** A minimum width of 900 mm to 920 mm clear transfer space shall be provided on one side of the toilet fixture measured from the edge of the toilet bowl (may be reduced to 760 mm if technically infeasible in a retrofit). Sanitary napkin disposal units may be installed if they are recessed or protrude no more than 100 mm into this space.
- 2.1.3** Toilet controls shall be electronically automatically controlled (for public toilets) or be hand-operated by a lever on the transfer side of the toilet. Refer to Figure 18.
- 2.1.4** Grab bars: one L-shaped, and one 600 mm to 760 mm long at the back mounted horizontally on the wall behind the toilet, from 840 mm to 920 mm above the floor, and, where the water closet has a water tank, be mounted 150 mm above the tank. Refer to Figure 19.
- 2.1.5** Toilet paper dispenser is to be reachable from a seated position and capable of being operated with one hand without binding.

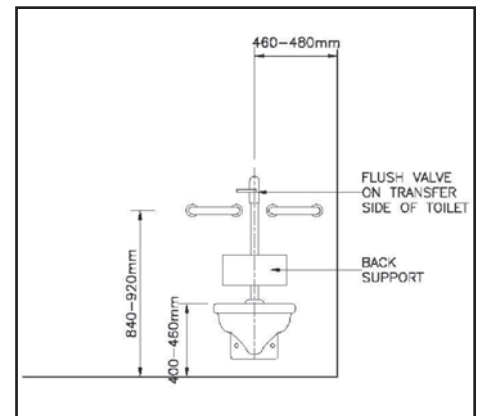

Figure 18

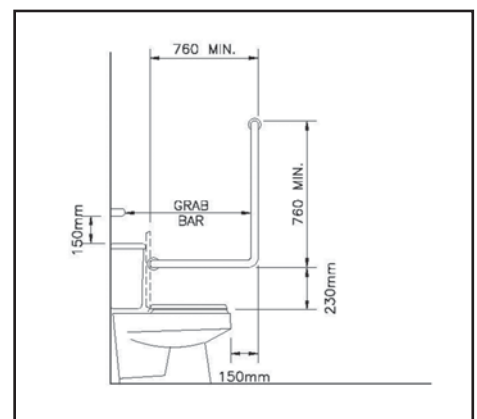

Figure 19

Note: This document is to be read in conjunction with the most current: "The Region of Peel Universal Accessibility Standards for Affordable Residential Properties" and "Crime Prevention Through Environmental Design" (CPTED) and/or any other document referenced in this document.

2.2 Lavatories/Hand Basins

- 2.2.4** Required minimum clear floor space 760 mm to 900 mm wide and 1,370 mm to 1,500 mm (4.5 ft. to 5 ft.) deep, of which a maximum of 480 mm in depth may be under the lavatory. Refer to Figure 20.
- 2.2.5** Insulate hot water and drain pipes if they abut the clearances noted above, or have the water temperature limited to a max. of 43 degrees Celsius (109.4 degrees Fahrenheit).
- 2.2.6** Have the hot water and drain pipes offset to the rear where possible.
- 2.2.7** Soap and towel dispensers shall have buttons/controls that are easy to operate with one hand.
- 2.2.8** Faucets and other controls shall have handles of the lever style (not self-closing or spring loaded), be angled to the front when in the off-position and be operable with a clenched fist. The length from the centre of rotation to the handle tip shall be at least 140 mm to 190 mm and rotate up to a maximum of 90 degrees. Controls are to be equipped with a pressure-equalizing or thermostatic-mixing valve. Faucets are to be single-handled lever. Automatic faucets are to be used for common area washrooms

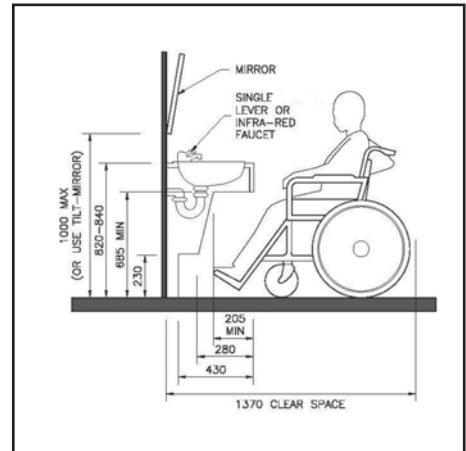

Figure 20

2.3 Washroom Accessories in Common Area Washrooms

- 2.3.1** Each type of washroom accessory provided, except those located in toilet stalls as specified in the Lavatory Section, shall have operable portions and controls mounted between 900 mm and 1,200 mm (3 ft. to 4 ft.) from the floor. Accessories such as towel dispensers and waste receptacles shall be placed close to the lavatory and not protrude into the path of travel. Also, hand dryers, paper towel dispensers and soap dispensers shall be installed directly adjacent to an accessible sink, but not encroach upon the required clear space.
- 2.3.2** Where mirrors are provided, at least one shall be 350 mm wide and mounted over wash basins with the bottom edge flush to the counter or sink.
- 2.3.3** Mirrors are to be mounted with the bottom edge no more than 915 mm to 1,000 mm (3 ft. to 3.3 ft.) from the floor. If a second mirror is to be provided, the bottom edge must be 780 mm from the floor and its top at 1,850 mm above the floor.

2.4 Individual/Family Washrooms

- 2.4.1** Be designed to permit a wheelchair to turn in an open space that has a diameter of no less than 1,500 mm (5 ft.).
- 2.4.2** Must be equipped with an accessible door as per Section 1.4.
- 2.4.3** Be equipped with a toilet so that its centre line is no less than 460 mm and no more than 480 mm from an adjacent wall on one side; and no less than 1,060 mm to the wall on the other side or to any fixture or other obstruction on the other side.
- 2.4.4** Must be equipped with grab bars conforming to Section 2.7.
- 2.4.5** Optional: be equipped with a fold-down grab bar at least 760 mm long at the open side of the toilet, mounted 420 to 440 mm from the centre line of the toilet and 630 mm to 690 mm above the floor.

Note: This document is to be read in conjunction with the most current: "The Region of Peel Universal Accessibility Standards for Affordable Residential Properties" and "Crime Prevention Through Environmental Design" (CPTED) and/or any other document referenced in this document.

2.4 Individual/Family Washrooms cont'd

- 2.4.6 Have a clear transfer space beside the toilet of 920 mm to 1,020 mm.
- 2.4.7 For common area washrooms, provide a collapsible coat hook mounted no more than 1,200 mm (4 ft.) from the floor on a side wall and projecting from the wall no more than 50 mm.
- 2.4.8 Have a shelf located no more than 1,000 mm above the floor in a location accessible to a person in a wheelchair. The shelf shall be colour-contrasting to the surrounding environment.
- 2.4.9 Comply with Section 2.2 Lavatories/Hand Basins.
- 2.4.10 Have a mirror and washroom accessories complying with the previous section.
- 2.4.11 Incorporate a change table. Refer to Figure 21.

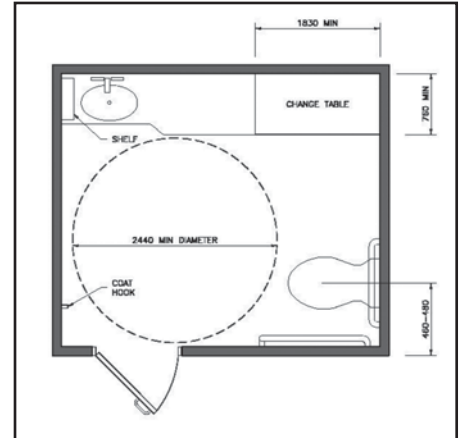

Figure 21

2.5 Bathtubs

- 2.5.1 Have a clear floor space at least 760 mm wide along the length of the bathtub (the lavatory can encroach a maximum of 300 mm into this space, provided there is clear knee space and toe space under the lavatory). Refer to Figure 22.
- 2.5.2 Have faucet handles that are automatically operable or of the lever type that are not spring-loaded and located so as to be usable by a person seated in the bathtub.
- 2.5.3 Faucets and other controls to be mounted above the bathtub rim not more than 450 mm to 460 mm. Refer to Figure 22.
- 2.5.4 Controls to be equipped with a pressure-equalizing or thermostatic-mixing valve, operable from the seated position and in compliance with Section 4.2.
- 2.5.5 Unless the bathtub is freestanding, it shall have an “L”-shaped grab bar, conforming to the Grab Bars Section mounted on the wall that is at least 1,220 mm long. Another grab bar shall be mounted vertically at the foot end of the tub adjacent to the clear floor space, with the lower end 180 mm to 280 mm above the bathtub rim. Refer to Figure 22.
- 2.5.6 Have soap holder(s), ideally to be fully recessed, which can be reached from the seated position.

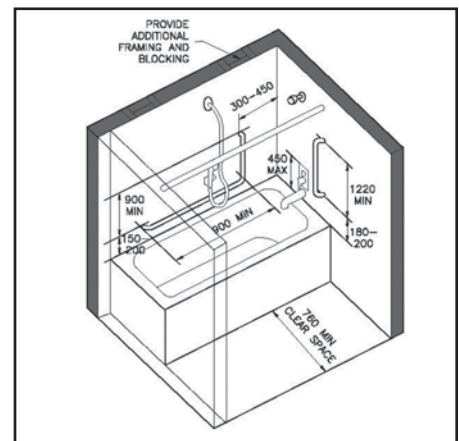

Figure 22

2.6 Shower Stalls in Barrier-Free Suites (Refer to Figure 23)

- 2.6.1 Have a dimension of 1,500 mm x 900 to 1,500 mm (5 ft. x 3-5 ft.) for a roll-in shower or 1,100 mm x 1,160 mm if equipped with a seat.
- 2.6.2 Locate the drain off to one side of the seat. Trench drains shall be avoided.
- 2.6.3 Where it is not technically feasible to remove the curb of the shower stall, a seat shall be provided on the long wall. It shall be at least 400 mm to 450 mm wide with its top between 430 mm and 480 mm from the floor.

Note: This document is to be read in conjunction with the most current: “The Region of Peel Universal Accessibility Standards for Affordable Residential Properties” and “Crime Prevention Through Environmental Design” (CPTED) and/or any other document referenced in this document.

2.6 Shower Stalls cont'd

- 2.6.4** Have an L-shaped grab bar with the horizontal portion at least 900 mm in length and mounted at 800 mm to 915 mm high.
- 2.6.5** Have a vertical grab bar that shall be 750 mm to 1,450 mm in length, mounted between 80 mm and 120 mm from the front edge, starting between 600 mm and 650 mm from the floor; and equipped with a pressure equalizing or thermostatic mixing valve, operable from the seated position and in compliance with Section 4.2.
- 2.6.6** Have a hand-held shower head with at least 1,525 mm of flexible hose, located so that it can be reached from the seated position, and equipped with a support so that it can be operated as a fixed shower head.
- 2.6.7** Have soap holder(s) that can be reached from the seated position, ideally fully recessed.
- 2.6.8** Controls for showers with a curb shall be mounted within reach of the seat; be no more than 1,200 mm from the floor (or 965 mm to 1,220 mm high for controls on a short wall beside the grab bar); and where the showerhead is mounted on a vertical bar, the bar shall be installed so as not to obstruct the use of the grab bar. A shower head shall be mounted to be adjustable between 1,200 mm from the floor and upward. Controls are to be equipped with a pressure-equalizing or thermostatic-mixing valve.

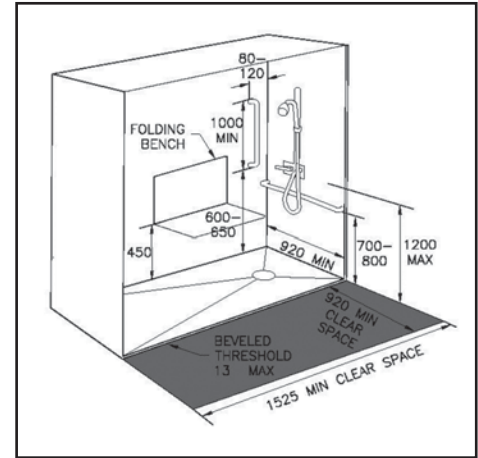

Figure 23

2.7 Grab Bars

- 2.7.1** To be no less than 30 mm and no more than 40 mm in diameter.
- 2.7.2** Have a clearance of 30 mm to 40 mm from the wall with edges.
- 2.7.3** Have a slip-resistant surface and not rotate within their fittings.
- 2.7.4** All suite units are to have grab bars.

3.0 Other Amenities

3.1 Tables, Counters and Work Surfaces (Refer to Figure 24)

- 3.1.1** Laundry rooms and other common areas shall meet the requirements under this section.
- 3.1.2** Laundry room counters shall be multi-levelled.
- 3.1.3** Wheelchair seating spaces at accessible tables, counters and work surfaces shall incorporate a clear floor space of no less than 760 mm to 900 mm x 1,370 to 1,500 mm (2.5 - 3 ft. x 4.5 - 5 ft.).

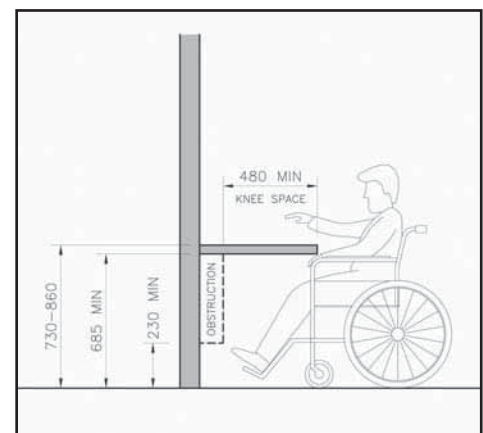

Figure 24

Note: This document is to be read in conjunction with the most current: “The Region of Peel Universal Accessibility Standards for Affordable Residential Properties” and “Crime Prevention Through Environmental Design” (CPTED) and/or any other document referenced in this document.

3.1 Tables, Counters and Work Surfaces cont'd

- 3.1.4** A forward approach for seating at tables and work surfaces is preferred with a clear knee space of at least 760 mm to 900 mm wide, 480 mm to 600 mm deep and 685 to 700 mm high. It may overlap the clear floor space by a maximum of 480 mm. Refer to Figure 25.
- 3.1.5** As depicted in Figure 24, the top of accessible tables, counters and work surfaces shall be located above the finished floor or ground by 710 mm to 865 mm (2.3 ft. to 2.8 ft.).

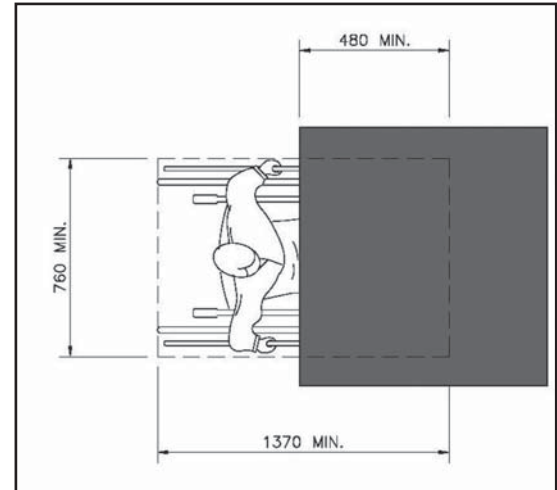

Figure 25

3.2 Information, Reception, Service Counters and Mailboxes

- 3.2.1** Counters for information or service shall incorporate at least one accessible section that is located above the finished floor or ground by 710 mm to 865 mm.
- 3.2.2** Required width is 915 mm to 920 mm
- 3.2.3** Accessible sections of information, reception, sales and service counters shall have, on both sides of the counter, knee space of at least 685 mm high x 480 mm. Refer to Figure 26.
- 3.2.4** Wheelchair seating spaces at accessible sections of information, reception, sales and service counters shall incorporate a clear floor space not less than 760 mm x 1,370 mm. Refer to Figure 26.
- 3.2.5** Where a forward approach is used to access a wheelchair seating space, a clear knee space of at least 760 mm wide, 480 mm deep and 685 mm high shall be provided. It may overlap the clear floor space by a maximum of 480 mm. See Figure 26.
- 3.2.6** Mailboxes or mail slots in apartment buildings, which are mounted between 610 mm and 1,065 mm from the floor, shall have the bottom two rows allocated for accessible use. A “D” type handle shall be provided for easy finger grip by persons with limited manual dexterity. A shelf shall be provided below the bottom of the mailbox for ease of sorting mail.

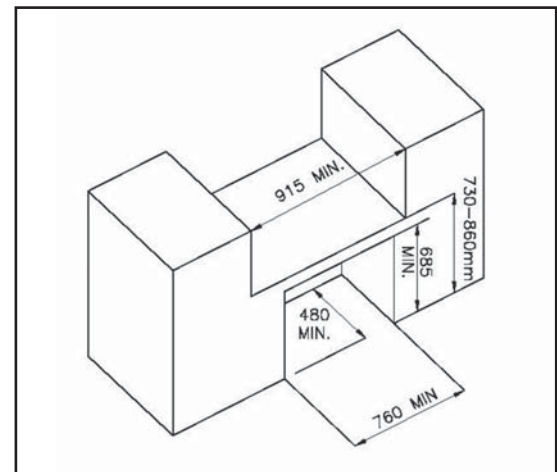

Figure 26

Note: This document is to be read in conjunction with the most current: “The Region of Peel Universal Accessibility Standards for Affordable Residential Properties” and “Crime Prevention Through Environmental Design” (CPTED) and/or any other document referenced in this document.

3.3 Storage and Shelving

- 3.3.1** A clear floor space of at least 760 mm x 1,370 mm that allows either forward or parallel approach by a person using a wheelchair shall be provided at accessible storage facilities.
- 3.3.2** Where the distance from the wheelchair to the clothes rod or shelf is between 255 mm and 535 mm (as in closets without accessible doors) the height of the rod or shelf shall be no more than 1,200 mm.
- 3.3.3** Where shelves are provided, there shall be at least three levels between 400 mm and 1,200 mm from the floor.
- 3.3.4** Where coat hooks are provided, they shall all be collapsible, mounted no higher than 1,200 mm from the floor and shall not be located over benches.

3.4 Parking

- 3.4.1** The required total number of parking spaces (visitor parking included) to the number of parking spaces designated to accommodate persons with disabilities shall be: 1-25 = 2; 26-50 = 3; 51-75 = 4; 76-100 = 5; 101-150 = 5%; 151-200 = 5%; 201-300 = 5%; 301-400 = 5%; 401-500 = 5%; 501 to over 2,000 = 5% of total.
- 3.4.2** Note that not all accessible spaces have to be wider. For example, some users do not require wheelchairs; however, they cannot walk very far. Allocation of such parking spaces shall be close to the building and would be an operational issue.
- 3.4.3** In facilities with multiple accessible entrances with adjacent parking, accessible parking spaces shall be dispersed and located closest to the accessible entrances; to be within 30 m of the main accessible entrance and/or any other accessible entrances.
- 3.4.4** The walkway from designated parking to the accessible entry to the building shall be no less than 1,100 mm in width and must be firm, level, non-slip material with a texture contrasted with the adjacent surfaces.
- 3.4.5** Where covered or underground parking spaces for cars are provided, all access and exit routes, including ramps serving such spaces, shall have clear headroom of 2,100 mm below beams, pipes or sprinkler heads; however, 2,285 mm is recommended. If vans are to be used, 2,900 mm is recommended.
- 3.4.6** Width and adjacent aisle width are to be as per Figure 27.
- 3.4.7** Where surfaces are paved, access aisles must be clearly indicated by markings of a contrasting colour, preferably yellow.
- 3.4.8** Parallel parking spaces: Dimensions to be as per Figure 28.
- 3.4.9** Where two accessible parking spaces are located together, the parking spaces may share a common access aisle. Colour contrasted bollards or curbs shall be used to prevent parked vehicles from protruding into the accessible circulation route. The distance between the bollards or curbs shall allow the passage of a wheelchair.

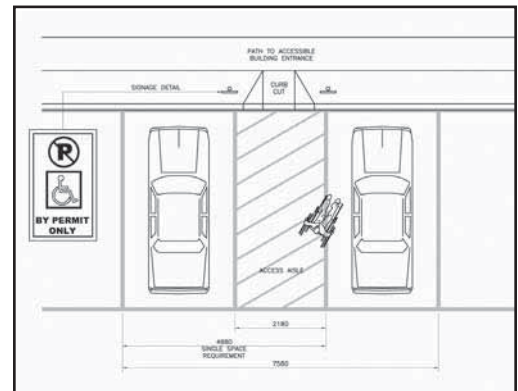

Figure 27

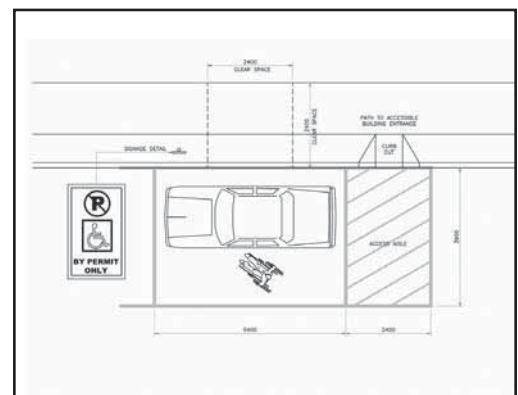

Figure 28

Note: This document is to be read in conjunction with the most current: “The Region of Peel Universal Accessibility Standards for Affordable Residential Properties” and “Crime Prevention Through Environmental Design” (CPTED) and/or any other document referenced in this document.

3.4 Parking cont'd

3.4.10 Accessible parking spaces shall be designated as being reserved for use by persons with disabilities.

3.4.11 Signage of parking spaces is to include an official designated disabled parking space sign in compliance with the City Traffic By-law mounted vertically; and an international symbol of access on the pavement of the stall.

3.5 Passenger Loading Zones

3.5.1 As illustrated in Figure 29, passenger loading zones must provide an access aisle of at least 2,440 mm (8 ft.) wide and 7,000 mm (23 ft.) long, adjacent and parallel to the vehicle pull-up space. Width may be 2,000 mm if technically infeasible in a retrofit.

3.5.2 Have a minimum vertical clearance of 900 mm (3 ft.) at the loading zone and along the vehicle access route to such areas to and from the site entrances (for TransHelp buses, the headroom clearance is recommended to be increased to 3,555 mm - 11.7 ft.).

3.5.3 Where it is feasible, covered passenger pick-up areas are recommended.

3.5.4 All designated passenger loading zones shall have a sidewalk or safe pedestrian zone, be located behind the vehicle and at the passenger boarding side of the vehicle, and be a minimum of 2,000 mm wide by the length or width of the boarding space, to ensure safe loading and unloading (2,400 mm wide x 1,800 mm long sidewalk for bus side lift).

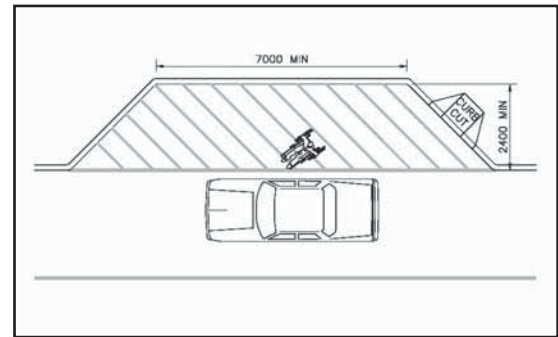

Figure 29

4.0 Systems and Controls

4.1 Areas of Rescue

4.1.1 Emergency evacuation chairs (compact and foldable mobile chairs) shall be available to firefighters. A designated holding area with back-up power for those who use portable ventilators is required. Extra receptacles are required at grade level.

4.1.2 Where emergency warning systems are provided, they shall include both audible alarms and visible alarms. Visual alarms shall comply with the standard stated in Section 4.3.

4.1.3 A horizontal exit meeting the requirements of the Ontario Building Code shall satisfy the requirements for an area of rescue assistance.

4.1.4 Occupant load of the floor area served by the area of rescue assistance/minimum number of rescue spaces: 1 to 400/2, over 400/3 plus 1 for each additional increment of 200 persons in excess of 400 persons.

4.1.5 The size of the area of rescue must allow a minimum floor space of 850 to 900 mm x 1,370 mm to 1,500 mm (1.5 m² per wheelchair) per non-ambulatory occupant, with no fewer than two such spaces; separated from the floor area by a fire separation having a fire resistance rating at least equal to that required for an exit; served by an exit or firefighters' elevator; have separate emergency lighting and ventilation systems. A two-way voice communication system linked to a monitoring company shall also be provided.

Note: This document is to be read in conjunction with the most current: "The Region of Peel Universal Accessibility Standards for Affordable Residential Properties" and "Crime Prevention Through Environmental Design" (CPTED) and/or any other document referenced in this document.

4.2 Controls and Operating Mechanics

- 4.2.1** A clear, level floor area of at least 760 mm x 1,370 mm (2.5 x 4.5 ft.) shall be provided with controls and operating mechanisms, such as dispensers and receptacles.
- 4.2.2** The operable portions of controls and operating mechanisms, such as dispensers and receptacles, shall be located from the floor by 900 mm to 1,200 mm (3 ft. to 4 ft.). See Figure 30.
- 4.2.3** Hand-operated controls and operating mechanisms shall be operable with one hand, without tight grasping, pinching or twisting of the wrist, and with a force of less than 22N.
- 4.2.4** Flush mounted buttons or touch pads and screens without Braille present difficulty for individuals with low or no vision and shall be avoided or accompanied by an accessible alternative.
- 4.2.5** All duplex receptacles as well as cable or telephone outlets shall be mounted no lower than 400 mm (1.5 ft.) from the floor and no higher than 1,065 mm (3.5 ft.). See Figure 30 (e.g. above counters or work surfaces). Exception: where outlets are provided as components of systems furniture, these devices need not comply with this section provided they are installed in addition to electrical outlets required by the AHJ.
- 4.2.6 Optional:** Keep thermostat at standard height and use remote controlled thermostats. Thermostats are not to interfere with Corporate Energy initiatives.

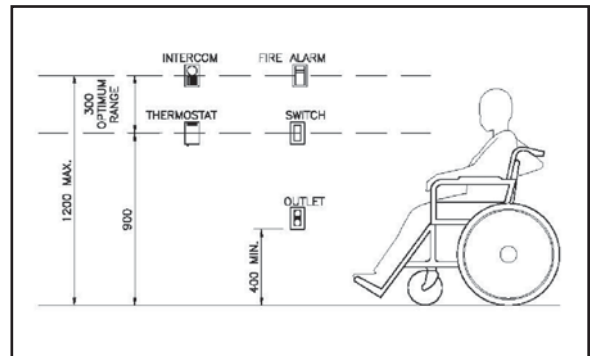

Figure 30

4.3 Visual alarms

- 4.3.1** Minimum of four alarms per suite are required: bedroom, bathroom, living room and kitchen. Note that combination horns/strobes are to be used in the living room and kitchen. Strobes only are to be used in the bedroom and bathroom.
- 4.3.2** Shall have the following photometric and location features:
- the lamp shall be a Xenon strobe type or equivalent;
 - the colour shall be clear or nominal white (i.e. unfiltered or clear filtered white light);
 - the maximum pulse duration shall be two-tenths of one second (0.2 sec) with a maximum duty cycle of 40 percent. The pulse duration is defined as the time interval between initial and final points of 10 percent of maximum signal;
 - the intensity shall be a minimum of 75 candelas;
 - the flash rate shall be a minimum of 1 Hz and a maximum of 3 Hz;
 - the appliance shall be placed 2,030 to 2,100 mm (~ 7 ft.) above the floor level within the space or 152 mm (~6 in.) below the ceiling, whichever is lower.

Note: This document is to be read in conjunction with the most current: “The Region of Peel Universal Accessibility Standards for Affordable Residential Properties” and “Crime Prevention Through Environmental Design” (CPTED) and/or any other document referenced in this document.

4.4 Signage

- 4.4.1** Signs that designate permanent rooms or spaces shall be wall mounted and include tactile characters and numbers.
- 4.4.2** Elements and spaces of accessible facilities that shall be identified by the International Symbol of Accessibility are:
- parking spaces, designated as reserved for individuals with disabilities
 - accessible passenger loading zones;
 - accessible ramps located in a barrier-free path of travel serving a building entrance;
 - accessible entrances when not all are accessible (inaccessible entrances shall have directional signage to indicate the route to the nearest accessible entrance);
 - accessible toilet and bathing facilities, including single-use portable units, when not all are accessible;
 - accessible telephones;
 - accessible elevators and other elevating devices;
 - accessible means of egress; and
 - areas of rescue assistance.
- 4.4.3** Install service animal signs as part of the AODA customer service regulations.
- 4.4.4** Letters and numbers on signs shall
- have a width-to-height ratio between 3:5 and 1:1;
 - have a stroke-width-to-height ratio between 1:5 and 1:10;
 - be sans serif;*
 - have Arabic numbers.
- 4.4.5** Character height dimensions for viewing distance shall comply with the following:
- minimum character height/max viewing distance = 25/750, 50/1500, 75/2300, 100/2500, 150/4600, 200/6000;
 - have a glare-free surface;
 - when used to give the same type of information within the same facility, be consistently shaped, coloured and positioned;
 - characters, symbols and backgrounds of signs shall have an eggshell, matte or other glare-free finish;
 - characters and symbols shall contrast with their background: either light characters on a dark background or dark characters on a light background;

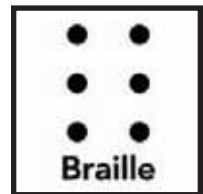

Note: This document is to be read in conjunction with the most current: “The Region of Peel Universal Accessibility Standards for Affordable Residential Properties” and “Crime Prevention Through Environmental Design” (CPTED) and/or any other document referenced in this document.

4.4 Signage cont'd

- use upper and lower case letters. Avoid using all capital letters as they provide less visual information to differentiate letters and give words shape; and
- clear path of travel shall be provided in front of all Braille and tactile signage.

4.4.6 Where signs are required to be tactile, letters and numerals shall be:

- raised 0.8 – 1.5 mm, not sharply edged;
- between 16 mm and 50 mm high;
- sans serif*, accompanied by Grade 2 Braille near the bottom edge of the sign; and
- colour contrasted with their background by at least 70%. Avoid using the colour combinations yellow/gray, yellow/white, blue/green, red/green, black/violet and red/black.

4.4.7 Where a tactile sign is provided, it shall:

- allow a person to approach the sign to within 100 mm without encountering protruding objects or standing within a door swing;
- have a clear wall area around the sign at least 75 mm wide;
- tactile signage shall be included in public areas, particularly at key access points, restroom entrances (to include vertical signage) and along emergency routes. They shall supplement the text of regulatory signs, such as prohibition and mandatory signs; warning signs, such as caution and danger signs; identification signs, such as rooms, titles, names or numbers; required at top and bottom of stairs;
- shall be mounted between 1.2 m (4 ft.) and 1.5 m (5 ft.) above the finished floor/ground;
- tactile signage at public entranceways and doorways shall be placed on the latch side of the door, no more than 150 mm (6 in.) from the door jamb. For restroom doors, tactile signage shall be placed on the door itself;
- the edges of tactile characters shall be gently rounded. Half-rounded characters shall not be used; and
- tactile characters shall measure between 16 mm (5/8 in.) and 50 mm (2 in.) in height. A minimum height of 25 mm (1 in.) is recommended for raised characters on identification signs.

4.4.8 Pictograms shall be accompanied by the equivalent verbal description, placed directly below the pictogram. The border dimension of the pictogram shall be minimum 150 mm in height.

4.4.9 Pictograms and symbols shall be:

- raised between 0.8 - 1.5 mm;
- placed on a sign at least 150 mm in height;
- accompanied by the equivalent description in Grade 2 Braille placed directly below the pictograph or symbol;
- colour contrasted with their background by at least 70%;
- lettering for room numbers or names shall be no smaller than 25 mm high in sans serif type print and be in a highly contrasting colour (70% or greater), compared with the background colour. Raised lettering is preferred for easy identification by persons with visual disabilities;

Note: This document is to be read in conjunction with the most current: "The Region of Peel Universal Accessibility Standards for Affordable Residential Properties" and "Crime Prevention Through Environmental Design" (CPTED) and/or any other document referenced in this document.

4.4 Signage cont'd

- for Braille users, Braille information shall be located immediately below all room numbers and names, as well as below any major directional signs;
- Grade 1 Braille shall be used on signage with 10 words or less, but be accompanied by un-contracted Braille (Grade 1) in signs with limited amounts of text (up to 10 words), and on all signs related to safety;
- Grade 2 Braille, which uses contractions of words and phrases, shall be used on signage with more than 10 words and be accompanied by contracted Braille (Grade 2) in all other applications;
- Braille type shall be in the same place as other type on all signs, e.g. below or to the left of the corresponding tactile sign;
- signs with Braille shall be positioned so that the reader does not have to bend over to touch the Braille type;
- Braille shall be separated from other raised characters or symbols; and
- where Braille is provided, the immediate surrounding surface shall be void of sharp edges or points.

4.5 Detectable Warning Surfaces

- 4.5.1** All textured surfaces used as detectable warning surfaces shall be cane-detectable and clearly differentiated from the surrounding ground or floor surfaces. (See also Section 4.10, Texture and Colour).
- 4.5.2** Detectable warning surfaces shall contrast visually with adjoining surfaces, being either light on dark or dark on light.
- 4.5.3** Interior detectable warning surfaces shall differ from adjoining surfaces in resiliency or sound upon cane contact, and shall be slip-resistant.
- 4.5.4** Detectable warning surfaces shall be at least 900 to 920 mm (35 to 36 in.) in width
- 4.5.5** Grooves, channels, thresholds or other changes in level found within a detectable warning surface shall have a maximum depth or height of 13 mm (1/2 in.).
- 4.5.6** Dot-type blocks shall be used to provide a warning signal to screen-off obstacles, drop-offs or other hazards. Dots shall consist of truncated domes with a diameter of 21 to 25 mm (~1 in.), a height of 4.5 mm to 5.5 mm (~1/4 in.) and centre-to-centre spacing of 55 to 65 mm (~2 in.). Refer to Figure 31.
- 4.5.7** Line-type blocks shall be used to indicate the correct direction of travel. Exterior line-type blocks shall consist of parallel grooves or incisions with centre-to-centre spacing of 75 mm (3 in.) to 100 mm (4 in.) and a maximum depth of 13 mm (1/2 in.). Example: across entire ramp width and length at a curb cut.

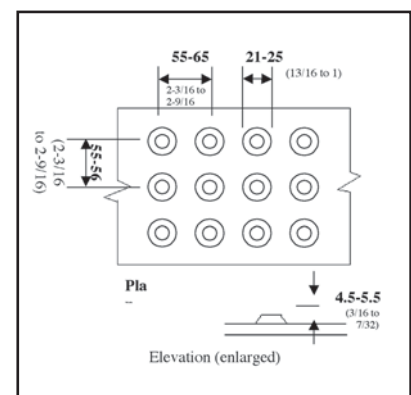

Figure 31

Note: This document is to be read in conjunction with the most current: “The Region of Peel Universal Accessibility Standards for Affordable Residential Properties” and “Crime Prevention Through Environmental Design” (CPTED) and/or any other document referenced in this document.

4.5 Detectable Warning Surfaces cont'd

4.5.8 Detectable warning surfaces at stairs shall:

- be provided at the top of the stairs and at landings;
- extend the full width of the stair commencing one tread depth back from the stair 920 to 1,200 mm (3 to 4 ft.) in depth. Refer to Figure 32; and
- not be more than 3 mm above or below the surrounding surface.

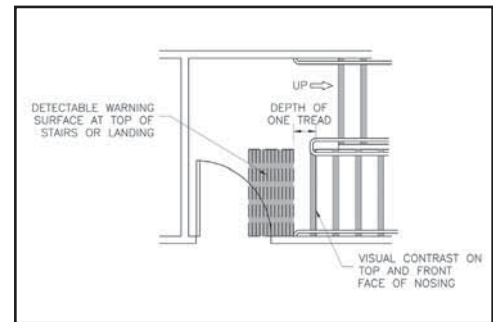

Figure 32

4.5.9 Detectable warning surfaces shall be located at:

- an unprotected drop-off edge (e.g. transit platform) where the change of elevation is greater than 250 mm, and the slope is steeper than in the ratio of 1:3 (33.3%);
- curb ramps (Curb Ramps Section);
- an entry into a vehicular route or area where no curbs or other elements separate it from the pedestrian route of travel such as traffic islands and pedestrian crosswalks; and
- If a walk crosses or joins a vehicular way and the walking surfaces are not separated by curbs, railings or other elements between the pedestrian areas and vehicular areas, the boundary between the areas shall be defined by a continuous detectable warning surface that is 920 mm (3 ft.) wide.

4.6 Card Access

- 4.6.1** Provide card access that is wall-mounted, adjacent to the door and free of the door swing. The centre of the control shall be located no higher than 1,000 to 1,200 mm (3 to 4 ft.) above the ground.
- 4.6.2** Provide an audible alarm and a light indicator to inform the user that the card has been accepted and allow the door lock to be disarmed.
- 4.6.3** A card slot shall be incorporated that is colour-contrasted from the mounting plate.
- 4.6.4** Use cards that incorporate a distinctive colour, texture or raised graphic/lettering on one side; include Braille as well.

4.7 Glare and Light Sources

- 4.7.1** Finishes such as vinyl, other composition materials, quarry tile, glazed tile or mosaics, used on horizontal surfaces, such as floors and work surfaces, shall be in matte or satin finishes. Extensive high-gloss floor finishes are not acceptable, but high-gloss materials may be incorporated into floor finish details, as long as they do not result in large reflective surfaces.
- 4.7.2** For common areas, curtains, blinds or other sun screening systems shall be provided at windows and other places where direct sunlight can adversely affect the level of lighting and/or reflected glare.
- 4.7.3** Light fixtures shall be selected with diffusers, lenses or recessed light sources, so that no glare is created.

Note: This document is to be read in conjunction with the most current: "The Region of Peel Universal Accessibility Standards for Affordable Residential Properties" and "Crime Prevention Through Environmental Design" (CPTED) and/or any other document referenced in this document.

4.7 Glare and Light Sources cont'd

- 4.7.3** Light fixtures shall be selected with diffusers, lenses or recessed light sources, so that no glare is created.
- 4.7.4** High intensity light sources such as quartz, halogen or other pin-point sources (e.g., chandeliers) shall be used with extreme caution. Such lighting sources are generally not recommended in circulation routes, dining or assembly areas because they are problematic for persons with low vision and produce reflected points of glare on shiny surfaces.
- 4.7.5** Changes in lighting level shall not exceed a range of 100 lux to 300 lux (10-30 ft. candles) from one space to the next.

4.8 Lighting

- 4.8.1** Artificial lighting and natural light sources shall provide comfortable, evenly distributed light at all working areas, in all circulation routes and in all areas of potential hazard. Outdoor lighting shall be provided at entrances, along frequently used access routes and at frequently used outdoor amenities. Adequate and controllable lighting is required for persons who lip-read, or those who require increased task lighting, due to visual impairment. Ample lighting shall be installed throughout a site, particularly at entrances, in work and meeting areas and areas of potential hazard, such as stairs or doorways.
- 4.8.2** Shall be evenly distributed to minimize cast shadows. Shields, recesses or other features shall be used to focus light and minimize reflective glare; and provide a good colour spectrum.
- 4.8.3** Supplementary lighting shall be provided to highlight key signage and orientation landmarks.
- 4.8.4** Exterior lighting shall be in compliance with the Illuminating Engineering Society of North America (IESNA). Standards in all public thoroughfares and at all pedestrian routes to provide safe access for persons with disabilities from sidewalks, bus stops and parking areas to nearby facilities and amenities.
- 4.8.5** Lighting levels at passenger drop-off areas shall be a min. 30 lux consistently over the drop-off area, measured at the ground.
- 4.8.6** Interior lighting shall comply with the following:
 - light sources and fixtures shall be selected to minimize direct glare or indirect glare on nearby reflective surfaces (e.g. use valence lighting versus sconces at suite door entrances);
 - light sources shall provide as full a spectrum of light as possible, as an aid to edge and colour definition. Where fluorescent or quartz light sources with a high blue content are used, the light quality shall be enhanced with incandescent lights to ensure the warm end of the spectrum is adequately present;
 - the leading edge of stairs, steps, ramps and escalators shall be evenly lighted to minimize tripping hazards;
 - lighting levels for interior accessible routes shall be at least 100 lux (10 ft. candles);
 - lighting levels in elevator lobbies shall be similar to the lighting levels in elevator cabs to minimize tripping hazards and measure 200 lux; and
 - lighting levels in washrooms and dressing rooms shall be evenly distributed and no less than 200 lux.
- 4.8.7** Lighting levels in office areas shall be evenly distributed and no less than 300 lux.
- 4.8.8** Emergency lighting over stairs and ramps, in an exit or path of travel, shall be less than 50 lux, but shall be at least 100 lux, generally at the walking surface.

Note: This document is to be read in conjunction with the most current: "The Region of Peel Universal Accessibility Standards for Affordable Residential Properties" and "Crime Prevention Through Environmental Design" (CPTED) and/or any other document referenced in this document.

4.8 Lighting cont'd

- 4.8.9** Lighting over directional or informational signage, or highlighting other orientation features, such as: at public telephones, information or service counters, card or keypad security systems, and at the working surface shall be no less than 200 to 250 lux.
- 4.8.10** Light fixtures with multiple pinpoints of high-intensity light shall be avoided, as they add an unnecessary source of glare and leave an after image on the retina for persons with low vision.
- 4.8.11** Wherever possible, natural light shall be utilized to assist in lighting entrances and corridors. However, care shall be taken to minimize direct glare that is problematic for persons with visual disabilities (e.g. reflected from floor or work surfaces).

4.9 Materials and Finishes

- 4.9.1** Proper flooring materials must be selected to ensure the safe and easy movement of persons using all kinds of mobility aids, as well as persons with low vision.
- 4.9.2** Stable, firm, slip-resistant materials and finishes shall be used wherever possible (refer to CAN/CSA B651 Annex D, "Potential for Slip of Floor and Tread Finishes").
- 4.9.3** Suitable paving surfaces for walkways include asphalt, concrete, compacted gravel screenings, interlocking brick and patio stones. Such materials used as walkways shall:
 - have joints that are no greater than 6 mm wide, with variations in level of no more than 3 mm;
 - be laid to drain;
 - where possible, gratings and grills shall be located to one side of pedestrian walkways, so as not to impede the accessible route. Where this is not possible, the bars of the grating or grill shall be located perpendicular to the dominant path of travel, with openings of no greater than 13 mm;
 - steps shall be finished with a slip-resistant material and incorporate highly contrasted nosings;
 - ramp surfaces shall be firm and non-slip;
 - handrails and guards shall be continuous, smooth and well maintained;
 - the finish of walls adjacent to ramps and stairs shall be non-abrasive; and
 - exterior surface materials shall be well-drained and installed to minimize water and ice accumulation.
- 4.9.4** Interior materials: Where hard, monolithic materials are selected, they shall be non-slip and non-glare, complying with Section 4.7.1.

4.10 Texture and Colour

- 4.10.1** Exterior colour schemes shall incorporate a pronounced colour contrast to differentiate boundaries of objects, distinguish objects from their background and to generally enhance spatial orientation. Generally, for seniors and persons with low vision, colours in the warm end of the spectrum (yellow, orange, bright red, etc.) are easier to recognize than those at the cool end of the spectrum.
- 4.10.2** Signs shall incorporate pronounced glare-free colour contrast. A minimum contrast of 70% light reflectance is required. For signs, the most visible colours are white or yellow on a black, charcoal or other dark background, such as brown, dark blue, dark green or purple. Black lettering on white is also acceptable, although less readable than the reverse. Unacceptable background colours are light gray and pastel colours. Red lettering on a black background is also unacceptable. For bright yellow, a 40% contrast is acceptable.

Note: This document is to be read in conjunction with the most current: "The Region of Peel Universal Accessibility Standards for Affordable Residential Properties" and "Crime Prevention Through Environmental Design" (CPTED) and/or any other document referenced in this document.

4.10 Texture and Colour cont'd

- 4.10.3** Colour contrast shall be used as a safety measure to define edges or boundaries of objects (e.g. stair nosings, doors, handrails, etc.). Colour or tone shall be used to visually define the boundaries of a room (i.e. where the wall meets the floor). Baseboards in monochromatic environments shall be highly contrasting with the wall and floor colours, to provide boundary definition. Doors and/or door frames shall incorporate pronounced colour contrast to differentiate them from the surrounding environment. Door handles and other operating mechanisms shall incorporate pronounced colour contrast to differentiate them from the door itself.
- 4.10.4** Suitable interior textures include raised domes, dots or squares, deeply grooved concrete, terrazzo or other stone-like materials, with closely centred grooves at right angles to the path of travel, or applied carborundum or other non-slip strips.
- 4.10.5** Supplementary textural cues shall also be provided (e.g. by using different floor textures or materials in major and minor routes).
- 4.10.6** Clearly-defined boundaries of materials like carpeting or floor tiles shall enhance way-finding by defining, for example, the junction between walls and floors, doorway recesses and corridor intersections.
- 4.10.7** Caution is recommended in the selection of heavy or distinct patterns on walls or floors since these can add visual confusion for persons with low vision or for persons with psychiatric disorders, if over-used. Simple, repetitive and non-directional patterns with low contrast are preferred (e.g. for carpeting, floor tiles, wall papers) in order to produce the least amount of visual confusion.

4.11 Heating, Cooling and Ventilation Systems (HVAC)

- 4.11.1** Heating, cooling and ventilation systems shall be designed to accommodate persons whose circulatory systems are inadequate. For instance, many seniors and persons using mobility devices have difficulty sensing temperature differences because of poor circulation or body tone. When the ambient temperature is too high or too low, they may become dehydrated or suffer from hypothermia.
- 4.11.2** Ambient air temperature in facilities serving persons who are either: frail, seniors or persons with disabilities shall be designed to operate between 21°C and 26°C (70°F and 79°F) at all times of the year to co-ordinate with energy and LEED standards.
- 4.11.3** The humidity in the air of residential facilities serving seniors or persons with disabilities shall be designed to operate between 30% - 40% (especially during the winter months), to aid proper skin care.
- 4.11.4** Mechanical, ventilation and air-cooling systems shall be designed so that the air flow from diffusers/grills is not directed towards persons lying in bed or toward permanent seating.

4.12 Acoustics

- 4.12.1** Floor finishes, wall surfaces and ceilings shall be selected so that occasional noise is not unduly amplified. (e.g. hard surfaces such as marble or terrazzo will allow each footstep to be heard by persons who are visually impaired, but add another level of confusion for persons who are hearing impaired.)
- 4.12.2** The Region of Peel Affordable Housing guidelines require the following sound transmission classes (STC):
- STC 52 between residential units;
 - STC 55 between residential units and other (no-residential) spaces; and
 - STC 60 between residential units and mechanical or electrical rooms, emergency generator room elevator room and/or elevator shaft (hoistway), service room and refuse chute.

Note: This document is to be read in conjunction with the most current: "The Region of Peel Universal Accessibility Standards for Affordable Residential Properties" and "Crime Prevention Through Environmental Design" (CPTED) and/or any other document referenced in this document.

5.0 Kitchens

5.1 Kitchen requirements

- 5.1.1** The clear floor space between counters and all opposing base cabinets, countertops, appliances, or walls in kitchens shall be at least 1,800 mm (6 ft.) regardless of U-shaped, L-shaped or other shaped kitchens (refer to Figure 33). Counters not situated against walls shall NOT be fixed to the floor so that they may be moved.

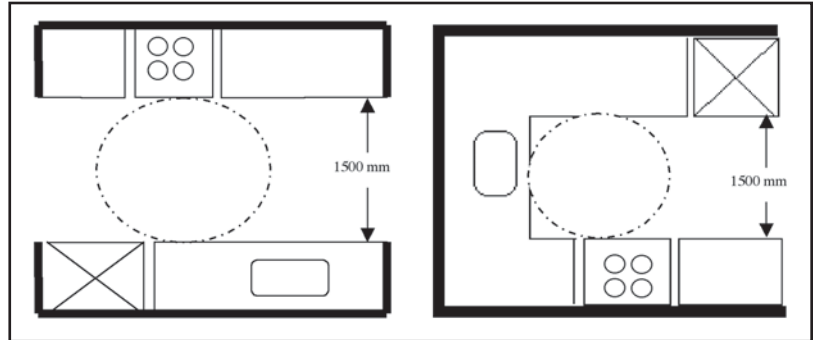

Figure 33

- 5.1.2** Additional lighting shall be provided over the sink, cooking and work surfaces to ensure safe use of facilities by persons with low vision or limited dexterity.
- 5.1.3** Refrigerators and freezers shall be vertical side by side, self defrosting with storage space and controls not more than 1.1 m (3 ft. 8 in.) from the floor.
- 5.1.4** At least one work surface shall:
- be 760 mm (2.5 ft.) wide x 610 mm (2 ft.) deep and a maximum height of 860 mm (2.8 ft.) measured from the floor;
 - have a clear floor area of at least 760 mm x 1,370 mm (2.5 ft. x 4.5 ft.), which may extend up to 480 mm (1.6 ft.) underneath the work surface;
 - have a centred knee clearance of at least 760 mm wide x 480 mm deep x 685 mm high;
 - with a toe space of a minimum 205 mm deep x 230 mm high; and
 - have electrical outlets at the side or the front of it.
- 5.1.5** A sink shall:
- with a maximum of 480 mm height underneath the sink, have a clear floor area of at least 760 mm x 1,200 mm to 1,370 mm;
 - be mounted so that the minimum distance between the centre line of the fixture and the side wall is 460 mm; with the top located from the floor by 710 mm to 860 mm to rim or countertop, whichever is higher;
 - have a knee clearance of at least 760 mm wide x 200 mm deep x 685 mm high;
 - with a toe space of 205 mm deep x 760 mm wide x 230 mm high;
 - have hot water and drain pipes offset to the rear and insulated if they abut the above noted clearances; and
 - have temperature control faucets.

Note: This document is to be read in conjunction with the most current: “The Region of Peel Universal Accessibility Standards for Affordable Residential Properties” and “Crime Prevention Through Environmental Design” (CPTED) and/or any other document referenced in this document.

5.1 Kitchen Requirements cont'd

5.1.6 A range and cook-top shall have:

- controls located where they do not require reaching across the burners to operate;
- a surface height of between 820 mm to 860 mm (2.6 ft. to 2.8 ft.) from the floor;
- adjacent work surface of at least 300 mm wide on both sides of the stove at the same height as the cook-top;
- a knee clearance centred on the cook-top at least 760 mm wide x 685 mm high; with a toe space 230 mm deep x 230 mm high;
- insulation or other protection on the underside where the knee clearance is provided, or the appliance is otherwise configured to prevent burns, abrasions or electrical shock; and
- a clear floor area of at least 760 mm x 1,370 mm, which may extend up to 480 mm underneath the cook-top.
- automatic off-switches to control unattended/unused burners. This also applies to ovens (e.g. Safe-T-elements).

5.1.7 An oven shall have controls located on the front panel and, for an oven equipped with a side-opening door, a horizontal surface shall be provided:

- controls to be mounted no higher than 1,400 mm (4.6 ft.);
- beside the latch-edge of the doors, a pullout shelf under the door that extends the width of the oven; pull-out at least 250 mm (10 in.);
- a work surface positioned adjacent to the latch side of the door; and
- where bottom-hinged doors are used, a work surface positioned adjacent to one side of the door.

5.1.8 Microwave ovens shall be mounted at counter height with the operating panel not more than 1,200 mm (4 ft.) from the floor.

5.1.9 Cabinets, drawers and shelf storage areas shall have:

- at least one shelf from the floor (where it is above a work surface) no more than 1,100 mm high (3.6 ft.);
- “D” type door pulls mounted close to the bottom of upper cabinet doors and top of base cabinet doors; and
- duplex receptacles (e.g. power outlets), where mounted above counter height, shall generally be no higher than 1,065 mm (3.5 ft.) from floor level. Duplex receptacles shall be located so that loose electrical cords do not cause a potential tripping hazard, especially for persons with visual limitations.

6.0 Maintenance

6.1 Housekeeping Considerations

- #### 6.1.1
- Despite all good intentions during the design stage of creating fully accessible environments, the success of the eventual project is largely dependent on decisions made by facility managers regarding space utilization, security and maintenance issues. Training for maintenance staff shall address potential barriers.

Note: This document is to be read in conjunction with the most current: “The Region of Peel Universal Accessibility Standards for Affordable Residential Properties” and “Crime Prevention Through Environmental Design” (CPTED) and/or any other document referenced in this document.

6.1 Housekeeping Considerations cont'd

- 6.1.2** Maintenance staff shall be educated to keep paths of travel free of added objects, including waste containers, recycling bins, planters, vending machines, dispensers, staff equipment and furniture, as these items may result in tripping hazards and limit movement for persons who have visual limitations. Aisle and corridor widths should also not be obstructed, as added items limit the maneuverability of persons using mobility aids (e.g. wheelchairs and scooters). Placement of waste receptacles in washrooms stalls, under a sink or hand dryer, and the storing of maintenance materials in accessible parking spaces shall not be allowed. Staff shall ensure that the pressure of opening mechanism of doors be reduced.
- 6.1.3** Temporary signs on stands or mounted on walls and doors can add confusion for persons with low vision. Proper planning and co-ordination is required.
- 6.1.4** Decisions on energy conservation often result in reduced lighting levels, potentially inhibiting safe movement through buildings for all users. Proper design is required and shall comply with Section 4.8.
- 6.1.5** Maintenance staff shall not wax or seal a typically non-glare floor surface (e.g. matte ceramic tile finish) to create a high-gloss polish/finish. A high-gloss finish can create glare problems for persons with visual limitations from overhead or adjacent natural lighting sources. High-gloss finishes on some floor surfaces also results in potential slipping hazards for all users, especially persons with low vision.
- 6.1.6** Maintenance staff shall not add runners or mats on floors in entrances, hallways and corridors during winter conditions in an attempt to minimize tracking. Adding such items may be disorienting for persons with low vision and it may also inhibit movement by persons using mobility aids (e.g. where mats become rolled or bunched up accidentally).
- 6.1.7** Snow removal: stockpiling of snow at or near accessible parking spaces defeats their purpose and shall not be allowed.

Note: This document is to be read in conjunction with the most current: “The Region of Peel Universal Accessibility Standards for Affordable Residential Properties” and “Crime Prevention Through Environmental Design” (CPTED) and/or any other document referenced in this document.

Appendix D

Region of Peel Metering Requirements



	SUPPLEMENTAL UTILITIES EQUIPMENT EBS-Real Property Asset Management-Energy Services	Issue Date:	Apr. 2006
		Review Date:	Dec. 2011
		Last Revised:	Jan. 2011

Main Utilities - Supplemental Equipment and Wiring for all Regional Indoor Locations

This standard outlines requirements for the equipment, installation and wiring (Electrical and Communications) for connections from Electrical, Natural Gas and Water meters to the Corporate Energy Management’s main communications panel.

The proponent shall:

- 1) Adhere to the concept sketch, Schematic A, which details the design for the main utilities supplemental equipment and wiring for the Region of Peel indoor metering locations.
- 2) Supply and install an electrical panel of size no less than 2 in. x 2 in. x 10 in. NEMA 1 in the main electrical room. This panel shall have a backboard for mounting electrical devices and shall have a clasp for locking with a padlock. The clasp shall be large enough to fit a Guard model 834A 1 ½ in. padlock. Padlock supplied by others. This panel shall have one terminal strip (12 positions) mounted on the backboard (for the connection of instrumentation wiring) and shall have a 120VAC double receptacle mounted on the backboard. Label this panel “Corporate Energy Management Equipment” (referred to hereafter as the CEM Panel) with an engraved lamacoid nameplate (green background, white lettering) mounted in the upper right corner on the outside of the panel.
- 3) Mount this CEM Panel on the wall of the main electrical room, within 5 feet of the existing main electrical meter panel where possible.
- 4) Install a new double electrical outlet in the existing utility electrical meter panel. This installation will require co-ordination with the local utility to arrange access to this panel.
- 5) Supply and install an electrical panel large enough to contain 1 – 30 amp 240VAC disconnect switch and a 4 circuit breaker panel (each circuit breaker to be 15 amp 120VAC). Supply and install the disconnect switch and the 4 circuit panel and install them in this electrical panel. Label this panel “Power Supply for CEM Panel” and mount this panel on the wall close to the CEM Panel. This panel is to have a clasp for locking with a padlock. The clasp shall be large enough to fit a Guard model 834A 1 ½ in. padlock. Padlock supplied by others.
- 6) Run three-wire 120VAC wiring from the existing building splitter downstream of the existing building transfer switch to the Power Supply for CEM Panel and then to the double electrical outlet in the CEM Panel and then to the double electrical outlet in the existing utility electrical meter panel, (see concept sketch, Schematic A). Wiring gauge should be sized appropriately as per ESA standards with the distances of the wiring runs involved and all wire must be run in conduit. The conduit running from the CEM Panel to the existing utility electrical meter panel must have a minimum inner diameter of two inches.
NOTE: Bend radius must be of a diameter sufficient to install a 1 ¾ in. cable.
- 7) Supply an intrinsic barrier (must be a R. Stahl model 9170/20-12-21). The barrier must be mounted on DIN rail in the CEM Panel. Supply a NEMA 4X (gas splice box) to contain a 6-position terminal strip to splice together the signal cable from the intrinsic barrier to the gas meter cable, and mount this box within 3 feet of the gas meter. Supply and install the required cable harness for connecting the gas meter to the terminal strip in this new “gas splice box” (the cable harness must be Dresser Canada part number MISO46-000. (This is a standard cable of 6 feet in length. Dresser Canada should be contacted to order cables where required). All cables must be run in conduit.

Note: This document is to be read in conjunction with the most current: “The Region of Peel Universal Accessibility Standards for Affordable Residential Properties” and “Crime Prevention Through Environmental Design” (CPTED) and/or any other document referenced in this document.

- 8) Supply and install in conduit a quantity of 2 - 2 conductor FT6 shielded instrument cables - 18 gauge (1 to be connected, 1 spare) from the intrinsic barrier in the CEM panel to the gas splice box terminal strip.

NOTE: Conductors to be tested for continuity and labelled with the same numbering designation at each end of the cable.

- 9) Supply and install an electrical box 10 in. x 10 in. x 6 in. NEMA 1 (water splice box) mounted on the wall next to the building water meter, within 6 feet of the water meter if possible, in the water meter room, with a 6-position terminal strip inside the box. This box shall have a clasp for locking with a padlock. The clasp shall be large enough to fit a Guard model 834A 1 ½ in. padlock. Padlock supplied by others. This box shall have at least one free knock-out and stuffing box to allow future (and not included in the scope of work) cables to be run from this box to the water meter itself. Supply and install a quantity of 4 - 2 conductor FT6 shielded instrument cables - 18 gauge from the terminal strip in the water splice box (two cables will be connected and one will be spare and one will be for dc power), in conduit, to the instrumentation terminal strip in the CEM Panel.

NOTE: Conductors to be tested for continuity and labeled with the same numbering designation at each end of the cable.

Main Utility Metering Requirements

Electric Meter

- Ion 8600 - P8600E0C0H6C1A4A-AA003 - 8600-9S-5A-ALV-60-ETHMDM-RMSEAL IMO PML 8600 Power Meter.

NOTE: 3-element meter specified, confirm with local utility on element specification (ordered by the Region of Peel)

- A-Base Adapter-9
- P850EB2 - 8600 Digital I/O W/ 15 ft. Cable PML 8600 I/O expander Card
- IONE5.5-DL - Ion Enterprise Device License
- Main utility electric meter to have pulse outs for kWh and kVArh

Natural Gas - Meter should be standard Enbridge issue with pulse output module if rotary meter.

Water Meter - Meter should be standard Region of Peel issue.

Scope of Work General Requirements

- 1) Building walls which must be core drilled for the purpose of running conduit and wiring, shall be scanned prior to drilling, at the expense of the contractor.
- 2) Where excavation is required to bury conduit, the contractor shall be responsible for having the "utility locates" services performed prior to excavation work. Buried conduits should be ½ in. rigid PVC, sealed at the both ends to prevent the ingress of water and debris, and should be buried at a minimum depth of 75 cm below grade.
- 3) The contractor shall be responsible for procuring all required permits and carry out all required regulatory inspections, at the contractor's expense.
- 4) The contractor shall be responsible for submitting As Built drawings at the completion of the work. Site drawings will be supplied as files in AutoCAD format (version 14) and As Built drawings shall be submitted in AutoCAD 2000 or 2004 format and shall show the routing of all conduit and cable runs, cable sizes, panel locations and the layouts of the new panels.

Note: This document is to be read in conjunction with the most current: "The Region of Peel Universal Accessibility Standards for Affordable Residential Properties" and "Crime Prevention Through Environmental Design" (CPTED) and/or any other document referenced in this document.

Schematic A – Electrical Wiring & Equipment Layout

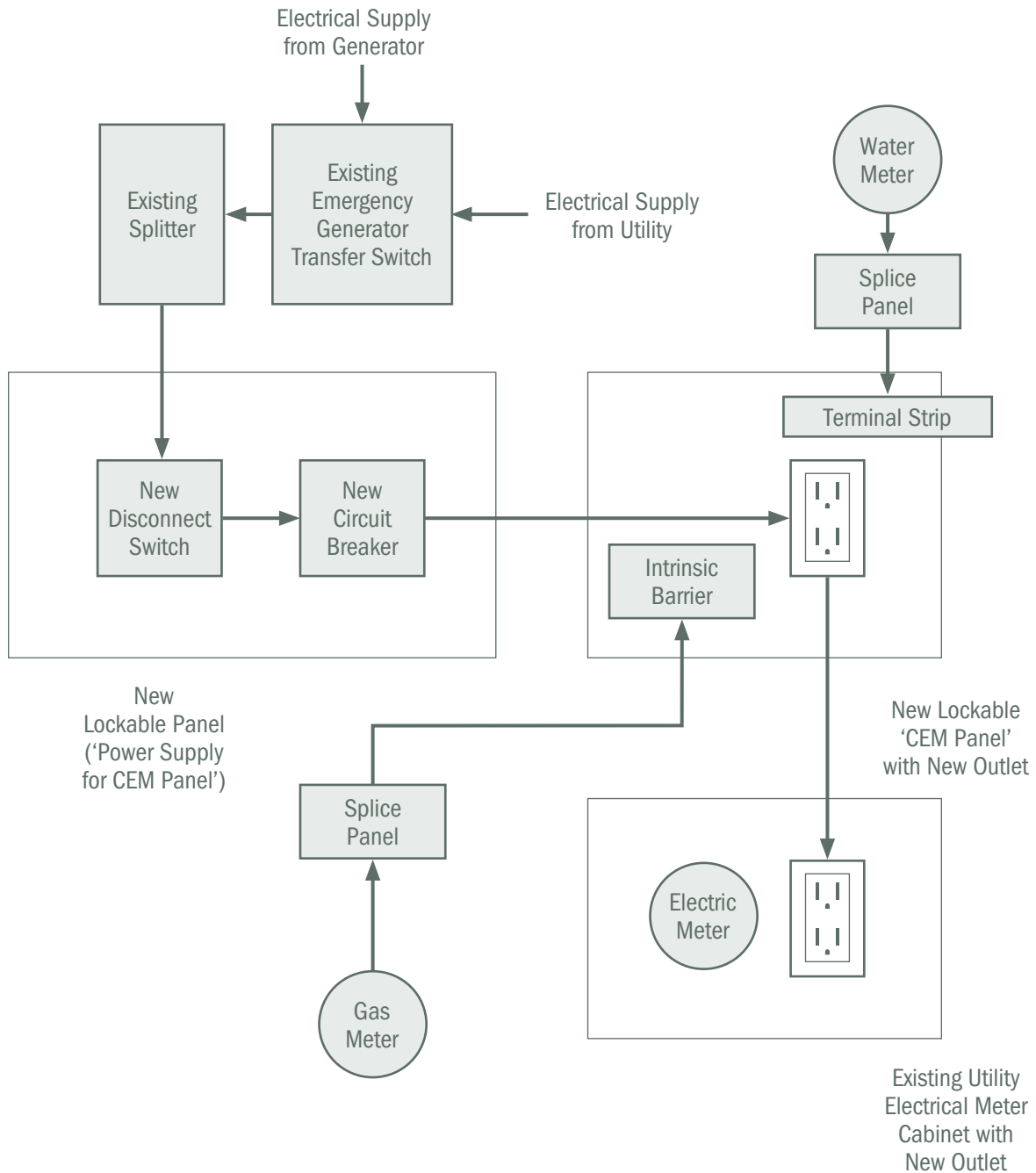

Note: This document is to be read in conjunction with the most current: "The Region of Peel Universal Accessibility Standards for Affordable Residential Properties" and "Crime Prevention Through Environmental Design" (CPTED) and/or any other document referenced in this document.

Appendix E

Building Automation Systems Specification

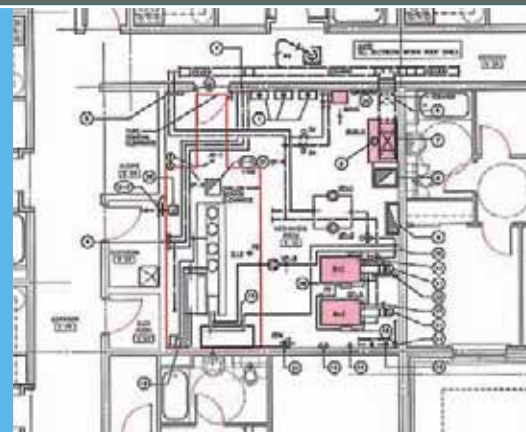

BUILDING AUTOMATION SYSTEMS PRODUCT STANDARD

INDEX

1	GENERAL
1.1	Overview
2	PRODUCTS
2.1	System Architecture
2.2	Network Router/Controllers (NRC)
2.3	Standalone Digital Control Units (SDCU)
2.4	Operator Workstation Requirements
2.5	BACnet Gateway to Third-party Devices
2.6	Region of Peel Minimum Computer Equipment Specifications

Note: This document is to be read in conjunction with the most current: “The Region of Peel Universal Accessibility Standards for Affordable Residential Properties” and “Crime Prevention Through Environmental Design” (CPTED) and/or any other document referenced in this document.

1.1 OVERVIEW

This document describes the acceptable product standard requirements for Building Automation Systems (BAS) to be installed in any building owned or operated by the Regional Municipality of Peel. Please note that this document is not a specification but serves as the guidelines to which all Building Automation Systems specifications must conform.

Fundamental System Requirements

1. All BAS devices residing on the enterprise network shall communicate with each other and comply with the following protocol standards:
 - a. ANSI / ASHRE BACnet Standard 135-2001 ..
 - b. ANSI / ASHRE BACnet / IP Standard 135-2001 – IP Addendum 135a
2. All BAS devices residing on the enterprise network shall communicate over IEE Standard 802.3 Ethernet wire.
3. All BAS devices residing on the enterprise network shall be able to reside on any standard IT network with no requirement for special hardware.
4. All BAS and IT devices used with the BAS must support the OSI Standard 7498-1 seven-layer model.
5. All BAS Server/workstation computers must meet the Region of Peel Desktop Equipment Specifications as given in Section 2.6, in addition to the BAS Product Standard. Designers should request the most up-to-date version of the Region of Peel Desktop Equipment Specifications.

2.0 PRODUCTS

2.1 System Architecture

General:

The Building Automation System shall consist of Network Router/Controllers (NRCs), a family of Stand-alone Digital Control Units (SDCUs), Administration and Programming Workstations (APWs), Web-based Operator Workstations (WOWs), and one File Server to support system configurations where more than three operator workstations are required. The BAS shall provide control, alarm detection, scheduling, reporting and information management for the entire facility, and Wide Area Network (WAN) if applicable, from a single ODBC-compliant database.

The system shall be designed with a top-level 10/100bT Ethernet network, using the BACnet/IP protocol. A sub-network using the BACnet MS/TP protocol shall connect the local stand-alone controllers with Ethernet-level controller/routers. The use of ARCNET, LON works, RS-232 serial communications, BACnet Ethernet or any other protocol for these controllers is not acceptable.

Level 1 Network Description:

Level 1, the main backbone of the system, shall be an Ethernet 10/100bT LAN/WAN, using BACnet/IP as the communications protocol. Network Router/Controllers, Operator Workstations, and the Central File Server shall connect directly to this network without the need for Gateway devices.

Level 2 Network Description:

Level 2 of the system shall consist of one or more BACnet MS/TP field buses managed by the Network Router/Controllers. The Level 2 field bus should consist of an RS485, token passing bus that supports up to 127 Stand-alone Digital Control Units (SDCU) for operation of HVAC equipment and lighting.

Note: This document is to be read in conjunction with the most current: “The Region of Peel Universal Accessibility Standards for Affordable Residential Properties” and “Crime Prevention Through Environmental Design” (CPTED) and/or any other document referenced in this document.

BAS LAN Segmentation:

The BAS network shall be capable of being segmented, through software, into multiple local area networks (LAN) distributed over a wide area network (WAN), sharing a single file server. This enables workstations to manage a single LAN (or building), and/or the entire system with all devices being assured of being updated by and sharing the most current database. In the case of a single-workstation system, the workstation shall contain the entire database with no need for a separate file server.

Standard Network Support:

All NRC, Workstation(s) and the File Server shall be capable of residing directly on the Region of Peel's Ethernet TCP/IP LAN/WAN with no required gateways. Furthermore, the NRC, Workstation(s) and File Server shall be capable of using standard, commercially available, off-the-shelf Ethernet infrastructure components such as routers, switches and hubs.

System Expansion:

The BAS system shall be scalable and expandable at all levels of the system using the same software interface, and the same Level 1 and Level 2 controllers. Systems that require replacement of either the workstation software or field controllers in order to expand the system are not acceptable.

The BAS shall be expandable to include and interface with video security and access control functions at any time in the future with no additional workstations, front-end software or Level 1 controllers required. It shall be possible to add Ethernet-based security/card access controllers to the existing Level 1 network, to perform security and card access applications. The system shall use the same application programming language for all levels: Operator Workstation, Network Router/Controller, and Stand-alone Digital Control Unit. Furthermore, this single programming language shall be used for all applications: environmental control, card access control, intrusion detection and security, lighting control, leak detection/underground storage tank monitoring and digital data communication interfaces to third-party microprocessor-based devices.

Support for Open Systems Protocols:

All hardware and software included under this section shall conform to BACnet standard 135-2001, to promote interoperability between building subsystems. Additionally, the BAS specification and design must include solutions for the integration of the following "open systems" protocols: LonTalk™, Modbus, and digital data communication to third-party microprocessors such as chiller controllers, fire panels and variable frequency drives (VFD).

The system shall also provide the ability to program custom ASCII communication drivers, which will reside in a BACnet Gateway, for communication to third-party systems and devices. These drivers will provide real-time monitoring and control of the third-party systems. Once programmed, these data points shall be monitored and controlled in exactly the same manner as native BAS data points.

2.2 Network Router/Controllers (NRC)

General:

Network Router/Controllers shall be classified as "native" BACnet devices, supporting the BACnet Building Controller (B-BC) profile. Controllers that support a lesser profile such as B-SA are not acceptable. NRCs shall be tested and certified by the BACnet Testing Laboratory (BTL) as Advanced Application Controllers (B-AAC), or be in the process of being tested and certified.

Hardware

Memory:

Both the operating system of the controller, plus the application program for the controller, shall be stored in non-volatile, FLASH memory.

Note: This document is to be read in conjunction with the most current: The Region of Peel Universal Accessibility Standards for Affordable Residential Properties" and "Crime Prevention Through Environmental Design" (CPTED) and/or any other document referenced in this document.

Communication Ports:

Each NRC shall provide communication to both the Workstation(s) and the field buses. An on-board 10/100bT Ethernet port shall be provided, as well as a RS-485 port for communications to a maximum of 127 MS/TP devices.

Automatic Restart after Power Failure:

Upon restoration of power after an outage, the NRC shall automatically and without human intervention: update all monitored functions; resume operation based on current, synchronized time and status, and implement special start-up strategies as required.

Battery back-up:

The NRC shall include an on-board battery to back up the controller's RAM memory. The battery shall provide accumulated back-up of all RAM and clock functions for at least 30 days.

Software

The application software shall be user programmable. This includes all strategies, sequences of operation, control algorithms, parameters and setpoints. The source program shall be English language-based and programmable by the user. Controllers that use a "canned" programming method are not acceptable for NRC.

Alarm Management:

All alarms should be tested on each scan of the NRC and all the results should be displayed in one or more alarm messages or reports. In the event of a communication interruption or failure, the alarm should be time-stamped and buffered in the NRC and then transmitted to the Operator Workstation if the point is still in the alarm condition when communications return. Alarms must be capable of being routed to any BACnet workstation that conforms to the B-OWS device profile and uses the BACnet/IP protocol.

Embedded Web Server:

Each NRC must have the ability to serve out customized web pages containing any desired I/O values from the entire BAS.

2.3 Stand-alone Digital Control Units (SDCU)

General:

Stand-alone Digital Control Units shall provide control of HVAC and lighting, including air handling units, rooftop units, variable air volume boxes, heat pumps, unit ventilators and other mechanical equipment. Each controller shall be fully programmable and contain its own control programs and will continue to operate in the event of a failure or communication loss to its associated NRC. Each SDCU provided must be a "native" BACnet device, supporting the BACnet Advanced Application Controller (B-AAC) or BACnet Application Specific Controller (B-ASC) profile. SDCU shall be tested and certified by the BACnet Testing Laboratory (BTL) as Advanced Application Controllers (B-AAC) or BACnet Application Specific Controller (B-ASC).

Hardware

Memory:

Both the operating system of the controller and the application program for the controller shall be stored in non-volatile, FLASH memory. Controllers shall contain enough memory for the current application, plus required history logging, plus a minimum of 20% additional free memory.

Communication Ports:

SDCU shall have an RS-485 communication port to the BACnet MS/TP field bus.

Note: This document is to be read in conjunction with the most current: "The Region of Peel Universal Accessibility Standards for Affordable Residential Properties" and "Crime Prevention Through Environmental Design" (CPTED) and/or any other document referenced in this document.

Battery Back-up:

All SDCU shall store all programming in non-volatile FLASH memory. All SDCU except terminal controllers shall include an on-board lithium battery to back up the controller's RAM memory. The battery shall have a shelf life of over 10 years and provide accumulated back-up of all RAM and clock functions for at least 3 years. In the case of a power failure, the SDCU shall restart itself from the RAM memory. If that memory is corrupted or unusable, then the SDCU shall restart itself from its application program stored in its FLASH memory.

VAV Terminal Unit Controllers:

VAV Controllers shall conform to the BACnet Advanced Application Controller (B-AAC) or BACnet Application Specific Controller (B-ASC) device profile. VAV Controllers shall be tested and certified by the BACnet Testing Laboratory (BTL) and be able to communicate with any other Stand-alone Digital Control Unit on the same MS/TP field bus.

Unitary Controllers:

Unitary Controllers shall conform to the BACnet Advanced Application Controller (B-AAC) or BACnet Application Specific Controller (B-ASC) device profile. Unitary Controllers shall be tested and certified by the BACnet Testing Laboratory (BTL) and be able to communicate with any other Stand-alone Digital Control Unit on the same MS/TP field bus.

2.4 Operator Workstation Requirements

General:

The operator workstation portion of the BAS shall consist of one or more full-powered configuration and programming workstations and one or more web-based operator workstations. The programming and configuration workstation software shall be configurable as either a single workstation system (with a local database) or multi-workstation system where the database is located on a central file server. The client software on multi-workstation system shall access the file server database program via an Ethernet TCP/IP network running at 100 Mbps. The web-based user interface software must be capable of expansion for a minimum of 10 concurrent users.

All workstation software, both programming and software and web-based operator software, shall conform to the BACnet B-OWS device profile, using BACnet/IP to communicate to other BACnet devices. All requirements for configuration and operating software are given in the Region of Peel Desktop Equipment Specifications in Section 10.6. The application software shall be capable of communication with all Network Router/Controllers and Standalone Digital Control Units, shall feature high-resolution colour graphics, alarming, reporting and shall be user configurable for all data collection and data presentation functions.

For multi-workstation systems, a minimum of 256 workstations shall be allowed on the Ethernet network along with the central file server. Multi-workstation systems with distributed/tiered file servers and a central (master) database are acceptable.

Web-based Operator PC Requirements:

Any user on the network must be able to access the system, using the following software:

- Windows 2000/XP/Vista
- Internet Explorer 6.0 and above
- Java-enabled

Web-based Operator Software:

Day-to-day operation of the system shall be accessible through a standard web browser interface, allowing technicians and operators to view any part of the system from anywhere on the network. Access to the system must be available from a dial-in connection over the Internet.

Note: This document is to be read in conjunction with the most current: The Region of Peel Universal Accessibility Standards for Affordable Residential Properties" and "Crime Prevention Through Environmental Design" (CPTED) and/or any other document referenced in this document.

Graphic Displays:

The browser-based interface must share the same graphical displays as the Administration and Programming workstations, presenting dynamic data on site layouts, floor plans and equipment graphics. The browser's graphics shall support commands to change setpoints, enable/disable equipment and start/stop equipment.

Through the browser interface, operators must be able to navigate through the entire system and change the value or status of any point in any controller. Changes must be effective immediately to the controller, with a copy stored in the system database.

Alarm Management:

Through the browser interface, a live alarm viewer identical to the alarm viewer on the Administration and Programming workstations shall be presented, if the user's password allows it. Users must be able to receive alarms, silence alarms and acknowledge alarms through a browser.

Schedules:

Through the browser interface, operators must be able to change schedules – change start and stop times, and add new times to a schedule.

2.5 BACnet Gateway to Third-party Devices

General:

Where a BACnet Gateway must be used to interface with an existing non-BACnet system that use the Modbus protocol, LONworks protocol or other proprietary protocol. The Gateway shall communicate directly over Ethernet TCP/IP and shall use the BACnet/IP protocol to communicate with a BACnet Workstation (B-OWS).

Communication Ports:

In addition to its on-board Ethernet port, the Gateway shall have at least two serial communications ports for interfaces to third-party systems.

2.6 Region of Peel Minimum Computer Equipment Specifications

Only those computer manufacturers identified as “Leaders” under Gartner Research’s Magic Quadrant for Global Enterprise Desktop PCs 2H04, or their respective authorized resellers, are acceptable suppliers.

Desktop Configuration

1. The complete system must be CSA-approved and shall meet the Canadian Equivalent of FCC Class B Emission Standards. Supporting documentation showing this certification shall be provided upon request.
2. Vendors are requested to select the appropriate model(s) from their product line suitable for business use. The basic configuration will include the following:

Note: This document is to be read in conjunction with the most current: “The Region of Peel Universal Accessibility Standards for Affordable Residential Properties” and “Crime Prevention Through Environmental Design” (CPTED) and/or any other document referenced in this document.

Specifications for Desktop Computers

Processor:	Intel® Core2 Duo E8400 3GHz 6MB L2 cache 1333 MHz FSB
Chipset:	Intel® Q45 Express
Memory:	2GB
Hard Drive:	160GB
USB Interface:	(v2.0) x8 Ports - (x6 Rear, x2 Front)
Floppy Drive:	No floppy drive
Optical Drive:	CD RW/DVD RW
Video:	Intel X-series GMA
Sound:	Integrated High-Definition Audio with ADI1884 codec (all ports are stereo)
Network Card:	10/100/1000 NIC
Mouse:	USB 2-button optical scroll mouse
Keyboard:	USB or PS/2 standard keyboard
Operating System:	Windows XP SP2

Specifications for LCD Flat Panel Monitor

The basic configuration of the system unit will include the following:

Specifications are based on a 17" LCD flat panel monitor that accounts for a majority of the requirement,; 19" and 23" must also be made optionally available.

Resolutions	640 x 480 @ 60 Hz and 75 Hz, 800 x 600 @ 60 Hz and 75 Hz 1024 x 768 @ 60 Hz and 75 Hz, 1280 x 1024 @ 60 Hz 75 Hz
Controls	Power, brightness, contrast, horizontal size and position, vertical size and position. (Digital controls with memory, preferred but not mandatory)
Stand	VESA 100 mm mounting option, height and tilt adjustable stand Built-in USB hub (optional)
Power Management	ENERGY STAR-rated
Sound	Monitor should not have built in or external speakers

Note: This document is to be read in conjunction with the most current: The Region of Peel Universal Accessibility Standards for Affordable Residential Properties" and "Crime Prevention Through Environmental Design" (CPTED) and/or any other document referenced in this document.

Specifications for Laptop Computers

Processor:	Intel® Core™2 Duo processor P8600 (2.4GHz, 1066MHz FSB, L2 Display: 15.4" TFT display
Bus Speed:	800 MHz FSB
Chipset:	Intel® Q45 Express
Memory:	2GB
Hard Drive:	160GB
USB Interface:	(v2.0) x8 Ports - (x6 Rear, x2 Front)
Floppy Drive:	No floppy drive
Optical Drive:	DVD Super-Multi Double Layer Drive
Video:	NVIDIA Quadro NVS 150M 256MB
Sound:	Intel High-Definition Audio
Network Card:	Integrated Ethernet LAN - Built-in Wireless LAN Intel WiFi Link 4965AGN

Building Automation & Controls System Product Standard

Mouse:	Dual pointing - acupoint and touchpad with scroll function/separately
Keyboard:	Full size; 85 keys with 12 function keys
Modem:	V.92 Data / 56K fax
Bluetooth:	Bluetooth v2.0 + EDR (module included)
Parallel Port:	None
USB Port(s):	USB 2.0 (x3)
PC Card Slots:	1 PC Card slot supports one Type II PC Card
Port Replicator:	Optional
Docking Station:	n/a
Weight:	6.38 lbs./2.9 kg with 6 cell battery
Dimensions:	366 mm wide x 268 mm deep x 30.0/38.8 mm high
Miscellaneous:	2 memory slots total, built-in stereo speakers, direct 3D sound, lithium-iron battery

Note: This document is to be read in conjunction with the most current: "The Region of Peel Universal Accessibility Standards for Affordable Residential Properties" and "Crime Prevention Through Environmental Design" (CPTED) and/or any other document referenced in this document.

Appendix F

Abbreviations, Acknowledgements,
Bibliography and References



ABBREVIATIONS

AAC	Accessibility Advisory Committee
ADA	American Disabilities Act
AFF	Above Floor Finish
AHJ	Authorities Having Jurisdiction
ANSI	American National Standards Institute
AODA	Accessibility for Ontarians with Disabilities Act
ASHRAE	American Society of Heating, Refrigeration and Air Conditioning Engineers
ASTM	American Standards for Testing Methods
A/V	Audio-visual
AWMAC	Architectural Woodwork Manufacturers Association of Canada
BAS	Building Automated Systems
CACF	Central Alarm Control Facility
CBIP	Commercial Building Incentive Program
CCA	Canadian Construction Association
CDA	Canadian Disability Act
CFCs	Chlorofluorocarbons
CFL	Compact Fluorescent Light
CGSB	Canadian General Standards Board
CMHC	Canada Mortgage and Housing Corporation
COP	Coefficient of Performance
CPTED	Crime Prevention Through Environmental Design
CSA	Canadian Standards Association
CSC	Construction Specifications Canada
CSI	Canadian Specifications Institute
DDC	Direct Digital Control
DHW	Domestic Hot Water
EER	Energy Efficient Ratio
GFI	Ground Fault Interrupt
HHC	Heritage and Historical Society
HRAI	Heating, Refrigerating and Air Conditioning Institute
HRV	Heat Recovery Ventilator
HSA	Health and Safety Act
HVAC	Heating Ventilation and Air Conditioning
IESNA	Illuminating Engineering Society of North America

Note: This document is to be read in conjunction with the most current: The Region of Peel Universal Accessibility Standards for Affordable Residential Properties” and “Crime Prevention Through Environmental Design” (CPTED) and/or any other document referenced in this document.

Abbreviations cont'd

IIC	Impact Insulation Class
IT	Information Technology
LED	Light-Emitting Diode
LEED	Leadership in Energy and Environmental Design
Low-E	Low-Emissivity
MDF	Medium Density Fibreboard
MEC	Model Energy Code
MNECB	Model National Energy Code of Canada for Buildings
MOE	Ministry of the Environment
MOL	Ministry of Labour
Mpa	Mega Pascals
MPDA	Master Painters' and Decorators' Association
MTKA	Modified Turnkey Agreement
MTO	Ministry of Transportation
NBC	National Building Code of Canada
NC	New Construction
NFA	Net Floor Area
NRC	National Research Council
OBC	Ontario Building Code
OFC	Ontario Fire Code
OHSA	Ontario Health and Safety Act
PLD	Power Light Density
PM	Project Manager
PVC	Polyvinyl chloride
RFP	Request for Proposal
SCC	Standards Council of Canada
STC	Sound Transmission Class
TPO	Thermoplastic Polyolefin
TSSA	Technical Standards and Safety Authority
UAS	Region of Peel Universal Accessibility Standards for Affordable Residential Properties
ULC	Underwriters Laboratories of Canada
VOC	Volatile Organic Compounds
VSD	Variable Speed Drive
WSIB	Workplace Safety Insurance Board

Note: This document is to be read in conjunction with the most current: "The Region of Peel Universal Accessibility Standards for Affordable Residential Properties" and "Crime Prevention Through Environmental Design" (CPTED) and/or any other document referenced in this document.

Acknowledgements

1. Keith Ward, Former Commissioner of Human Resources
2. Steve Hall, Director of Real Property and Asset Management
3. AAC working group
4. Brett Barnes, CMHC
5. John D'Angelo and Mauro Maurati, Martinway Contracting

Bibliography

City of Toronto, Accessibility Design Guidelines. Diversity Management and Community Engagement, Strategic and Corporate Policy/Healthy City Office, 2004.

City of Mississauga, Accessibility Design Handbook. The Accessibility Advisory Committee, 2007.

City of Brampton, Accessibility Technical Standards. City of Brampton Ontarians With Disabilities Act (ODA) Staff Committee and Technical SubCommittee, 2005.

City of London, 2007 Facility Accessibility Design Standards. City of London Municipal Accessibility Advisory Committee, 2007.

Betty Dion Enterprises Ltd. and CIBFD, International Best Practices in Universal Design: A Comparative Study. Agriculture and Agri-Food Canada and The Canadian Food Inspection Agency, 2000.

References

Peel CPTED Advisory Committee. Crime Prevention Through Environmental Design Principles – 2006
<http://www.peelregion.ca/planning/cpted/CPTED-2006.pdf>

Region of Peel Accessibility Standards for Affordable Residential Properties – 2008. September 2008.

Canada Post requirements:

http://www.canadapost.ca/cpo/mr/assets/pdf/business/standardsmanual_en.pdf

Region of Peel Waste Management Design Standards Manual:

<http://www.peelregion.ca/pw/waste/reports/>

Erosion & Sediment Control Guideline for Urban Construction:

http://www.sustainabletechnologies.ca/Portals/_Rainbow/Documents/ESC%20Guideline%20-%20December%202006.pdf

Note: This document is to be read in conjunction with the most current: The Region of Peel Universal Accessibility Standards for Affordable Residential Properties” and “Crime Prevention Through Environmental Design” (CPTED) and/or any other document referenced in this document.

Region of Peel
Real Property Asset Management
Employee & Business Services
10 Peel Centre Drive, Suite B
Brampton, ON L6T 4B9
Tel: 905-791-7800
e-mail: rpam@regionofpeel.ca
www.peelregion.ca

