

water quality report

Alton Well Water Supply 2009



 Region of Peel
Working for you



water quality report

TABLE OF CONTENTS

<i>Our Vision</i>	2
1. Drinking Water General System Information	3
1.1 The Municipal Waterworks of the Community of Alton, Town of Caledon	3
1.2 Expenditure Information:.....	4
2. How is the Water Treated?	4
3. Ontario Drinking Water Compliance Information	5
4. How well did we do?	7
4.1 Operation	7
4.2 Customer Service – Quality and Efficiency	9
5. Drinking Water Quality Programs	10
5.1 Drinking Drinking Water Licensing Program	10
5.2 Source Water Protection	10
5.3 Watermain Renewal Program.....	12
5.4 Community Lead Testing Program	13
5.5 Watermain Flushing Program.....	14
5.6 Watermain Swabbing Program.....	14
5.7 Hydrant Inspection Program.....	14
5.8 Drinking Water Sampling Station Program.....	15
5.9 Private Well Abandonment Program.....	15
Appendix A	16
❖ Summary of Water Quality Parameters	16
Appendix B	29
❖ Frequently Asked Questions	31
❖ Report Accessibility	34

The header features a blue background with a wavy, liquid-like texture. In the upper left corner, there are several white bubbles of varying sizes. The text "water quality report" is centered in the upper half, with "water quality" in white and "report" in orange.

water quality report

Our Vision

“To be recognized as the Industry Leader in Public Works”

The Regional Municipality of Peel takes pride in ensuring that its residents are provided with clean and safe drinking water.

The Region of Peel treats water to prevent contamination and regularly tests its quality. In the year 2009 Peel has provided its consumers with excellent quality water. A number of tests were performed on thousands of water samples collected throughout the year, including testing for microbiological, inorganic and organic parameters. The 2009 results of the tests performed by the Region of Peel confirm high quality of drinking water and have been consolidated in this annual report.

If experiencing difficulty accessing or viewing the 2009 data results, please contact Water Quality Team at 905-791-7800 ext 4685 or at WaterQualityInquiries@peelregion.ca.

water quality report

1. Drinking Water General System Information

1.1 The Municipal Waterworks of the Community of Alton, Town of Caledon

Drinking Water Works Number: 220004000 (Caledon Village- Alton System)



The community of Alton, with a total population of 1554, is serviced by the Alton Drinking Water System. This system consists of a water treatment plant with a total of two municipal wells, a water storage stand pipe and a distribution network of about 10 km of watermains and 62 fire hydrants.

The Alton Water Treatment Plant houses Wells No. 3 and 4, which are deemed groundwater under direct influence of surface water. Water treatment includes primary and secondary disinfection by Sodium Hypochlorite followed by ultraviolet (UV) light disinfection.

Alton Wells No. 1 and 2 are located off-site and are out of service.

The Caledon Village drinking water system is interconnected to the Alton water system and serves as a back up supply. The Caledon Village and Alton water systems are classified as one drinking water system under the same water works number.

The Alton drinking water system is monitored and controlled 24 hours per day, 7 days a week through a computerized Supervisory and Data Acquisition (SCADA) system. The Alton treatment plant is equipped with a stand-by power generator to ensure operation continuity in an event of a power failure.

water quality report

1.2 Expenditure Information:

The Region of Peel staff determines capital spending priorities to eliminate unnecessary expenditures while maintaining its infrastructure. 2009 was a busy year for water projects and programs; the total expenses for Alton drinking water infrastructure are shown in Table 1:

Table 1. System Expenditure for Alton System in 2009

Significant Installations	Approximate Expenditure
Standpipe New Control Building	\$32,800
UPS System Upgrade	\$7,600
UV Maintenance Program	\$1,530
HVAC Repair	\$ 4,700

2. How is the Water Treated?

2.1 Water Treatment Plant (Wells No.3 and 4)

Water treatment consists of primary and secondary disinfection, which is achieved through a combination of Sodium Hypochlorite and ultraviolet (UV) light. The treated water is allowed to remain in contact with Sodium Hypochlorite for a period of time to ensure effective disinfection before serving the first consumer in the water distribution system.

The Alton treatment process and water distribution are presented in Figure 1.



water quality report

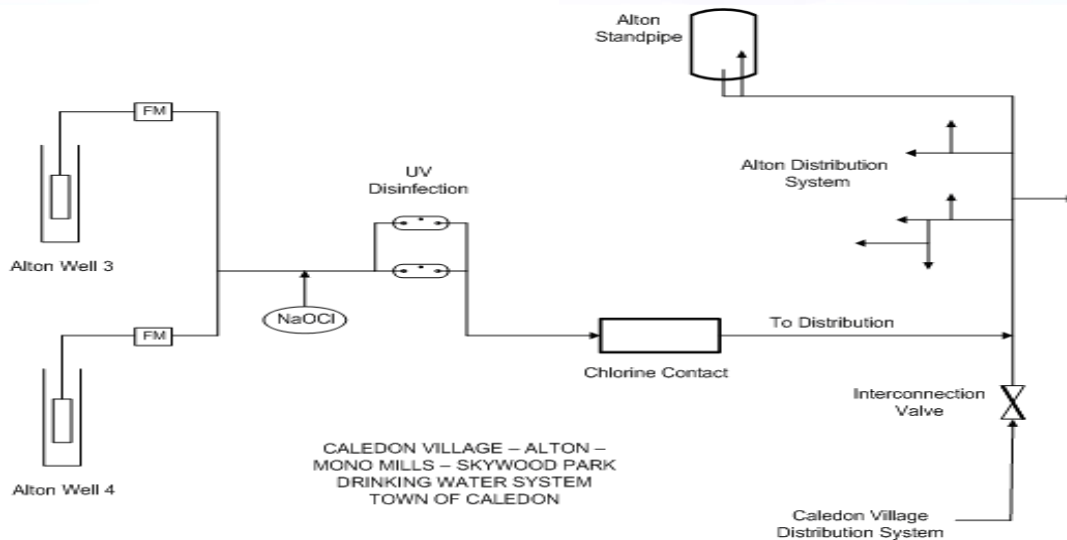

Figure 1. Water Treatment Process at the Alton System

3. Ontario Drinking Water Compliance Information

Drinking water quality in Peel is regulated by the Ontario Government through the Ministry of the Environment (MOE). The Ontario drinking water legislation sets requirements for municipal system owners with regards to the operation, level of treatment, sampling and testing, licensing of staff and water quality notification.

Water Quality Annual Reports

To comply with the Ontario drinking water regulation under the Safe Drinking Water Act (SDWA), the Region prepares Water Quality Reports providing information on quality of water supplied and a Summary Report regarding the operation of the drinking water systems.

The Summary Report under Schedule 22 of the Ontario Regulation 170/03 includes a statement of compliance of the Region of Peel's drinking water systems with the terms and conditions of the drinking water regulations under the Safe Drinking Water Act and a summary of the quantities and flow rates of water supplied. This report is made available by March 31 of each year.

The header features a blue background with a white and orange title 'water quality report'. The word 'water' is in white, 'quality' is in white with a blue shadow, and 'report' is in orange. The background includes a blue sky with a crescent moon and bubbles, and a white and blue wave pattern at the bottom.

water quality report

The Annual Reports are made available to the public to ensure Peel consumers are kept informed. Each year, the reports are posted on the regional web site and electronic or hard copies may be obtained upon request. The Region places an ad in the local newspapers to inform its consumers about the availability of the Annual Reports.

Sampling and Testing

In accordance with the drinking water legislation, drinking water systems are required to monitor their water quality to ensure it meets provincial standards. Peel regularly samples and tests raw, treated and distribution system water for a number of microbiological, chemical and radiological parameters. The Region has always had an extensive water sampling and monitoring program, to better understand the quality of source water, ensure effective treatment processes and to diligently monitor and protect the drinking water supply.

Sampling and testing is conducted by trained and qualified operators, who collect water samples from various sampling sites throughout the Region and immediately test them for water safety indicators. Samples are also collected for laboratory analysis for more than 150 health related and aesthetic parameters.

The MOE requires that all drinking water testing laboratories be accredited by Standards Council of Canada (SCC) based on proficiency evaluation conducted by the Canadian Association for Laboratory Accreditation (CALA) for all the water tests they perform.

Peel operates its own laboratory for chemical analyses and also subcontracts analytical testing to other area laboratories. All laboratories used by the Region are accredited and licensed by the Ministry of the Environment and adhere to strict drinking water sample collection, handling and transport protocols and procedures.

The header features a blue background with a white and orange 'water quality report' title. The background includes a stylized blue wave at the bottom, a cluster of white bubbles in the upper left, and a faint moon in the upper left corner.

water quality report

Licensed Operators

All treatment plant and maintenance operators and technical staff have appropriate Water Treatment, Water Distribution and Water Quality Analyst licenses, as required by Ontario drinking water legislation. The licensing and training program ensures that all operators are certified to industry recognized standards. Peel has established an ongoing continuing education program for all staff responsible for operating drinking water systems. This training program helps operators gain knowledge of the latest treatment technologies and advanced processes and efficiently maintain system water quality and quantity.

Water Quality Notification

In compliance with the regulatory requirements, Peel reports every adverse water quality event to the Ministry of the Environment and Ministry of Health and immediately initiates corrective action to address the problem. Peel has established a notification protocol for reporting of adverse water quality and makes these reports and data publicly available in the annual reports.

4. How well did we do?

4.1 Operation

To protect the health of the public and to ensure consumers receive clean and safe water, the Ministry of the Environment has established the Ontario Drinking Water Quality Standards (ODWS). These standards are set to ensure the water is free of disease causing organisms and hazardous and radioactive chemicals. In 2009, the Region monitored the water quality by undertaking over 85,000 process samples and tests to ensure safe and clean water supply. Appendix A summarizes the water quality test results according to the ODWS.

The Region of Peel is proud to report that for the year 2009, all drinking water samples met these standards. The Ministry of the Environment (MOE) performs annual inspections on all the water treatment plants. Based on the inspection outcomes the MOE issues score cards. The score is based on

water quality report

the questions posed by the Ministry inspector during each inspection. Alton's overall performance has been excellent for the past four inspection years.

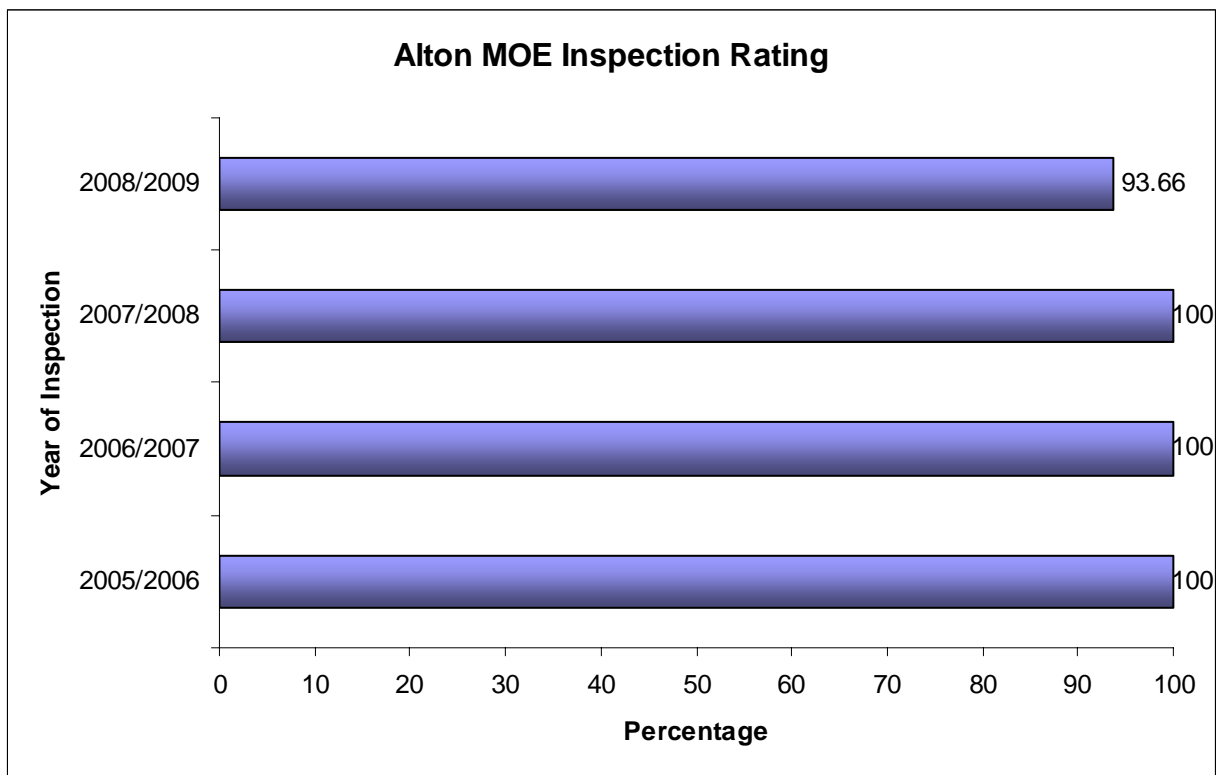

Figure 2: Ministry Inspection Results

During the period of January 1 through December 31, 2009, Alton met all the provincial requirements and ODWS except on one occasion, as presented in Table 2:

Table 2. Events in Alton Drinking Water System in 2009

Incident Date	Parameter	Result	Unit of Measure	Corrective Action	Date Reported to MOE
09-Jul-09	Sodium	97.6	mg/L	Alton Well #3 treated water was resampled and tested.	23-Jul-09

water quality report

4.2 Customer Service – Quality and Efficiency

In 2009, all customer calls were responded to and resolved in a timely manner. Peel staff has made every effort to contact the consumers in person and satisfactorily address their questions. Record of every water quality call received by Peel is logged in the regional data base and kept on file (see Figure 3).

The Community Lead Testing Program was initiated in 2007 and advertised in local newspapers. This may have accounted for the increase in the number of customer enquires reflected for 2007 and 2008 in the following chart.

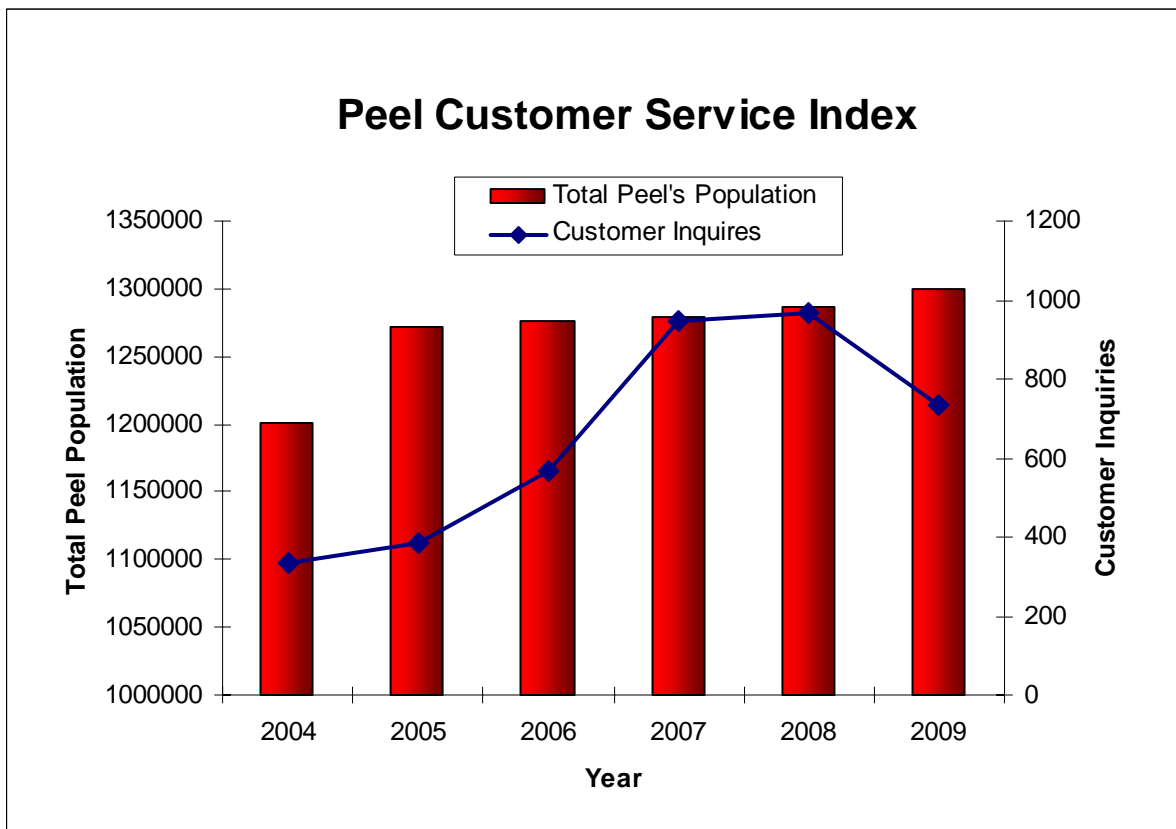

Figure 3. Customer Service in Peel Region Related to Water Quality

The header features a blue background with a white and orange 'water quality report' title. The background includes a stylized wave pattern and bubbles rising from the left side.

water quality report

5. Drinking Water Quality Programs

5.1 Municipal Drinking Water Licensing Program

The Ontario government has developed the Municipal Drinking Water Licensing Program (MDWLP) in support of the *Safe Drinking Water Act 2002*. The MDWL Program requires municipalities of drinking water systems to obtain: a Drinking Water Works Permit, a Permit to Take Water, an accepted Operational Plan, accreditation of the Operating Authority, and a Financial Plan for the operations of the water system. The Ministry of the Environment's intent is to ensure a culture of commitment to quality, diligence and dedication to consumers in the provision of drinking water.

As required by Ontario Regulation 188/07 (Licensing of Drinking Water Systems), the Region of Peel submitted an Operational Plan and applications for the Drinking Water Works Permits and Licenses for all its drinking water systems by January 1, 2009.

In late September 2009, the Region of Peel received accreditation by the Canadian General Standards Board (CGSB) for the desk top review of its Operational Plans ensuring conformance with the Drinking Water Quality Management Standard. The Region of Peel has since begun implementation of the quality management system, which must be completed within 12 months, followed by an on-site audit by CGSB to verify the Quality Management System's effectiveness.

In late November 2009, the Region of Peel received the Drinking Water Works Permits and Licenses for all of its drinking water systems.

5.2 Source Water Protection

In October 2006, the Ontario government passed the *Clean Water Act, 2006*, to protect drinking water at the source as part of an overall commitment to human health and the environment. The *Clean Water Act* came into force on July 3, 2007 with the release of regulations which enabled the creation of multi-stakeholder Source Protection Committees.



water quality report

The Clean Water Act, 2006 requires the development of drinking water source protection plans to address drinking water threats to all ground water and surface water municipal drinking water systems. Through continued collaboration with our Conservation Authority partners and the Province of Ontario, Peel Region initiated a number of studies to assist Source Protection Committees to develop source protection plans for all the watersheds from where our drinking water is supplied.

Groundwater Supply Protection

Peel was one of the first municipalities in Ontario to develop a Well Head Protection Area program for its municipal wells. This program focuses on identifying and protecting areas that replenish the municipal wells. As part of this program, the Region established a network of early warning wells in the vicinity of our municipal wells. Water level and water quality monitoring is conducted throughout the year at these early warning wells, which allows Peel Region to guard its groundwater supply against potential sources of contamination.

Surface Water Supply Protection

In partnership with the Source Protection Committees for Source Protection Regions abutting Lake Ontario, work is underway to assess the intake protection zones and drinking water threats for the drinking water supplies on Lake Ontario. The Collaborative Study to Protect Lake Ontario Drinking Water is a Peel Region led initiative that includes 19 municipalities, from Niagara Region to Prince Edward County along the Lake Ontario shoreline.

The Collaborative Project includes the following components:

- Lake wide models to evaluate physical processes in Lake Ontario and enable the delineation of intake protection zones for municipal water treatment plants.
- Watershed pollutant loading studies to evaluate pollutant loading to Lake Ontario.
- Identification of drinking water threats (chemical or pathogen) for each municipal drinking water intake.

The header features a blue background with a wavy, liquid-like texture. In the upper left corner, there are several white bubbles of varying sizes. The text "water quality report" is centered in the upper half. "water" is in white, "quality" is in white with a blue shadow, and "report" is in orange.

water quality report

5.3 Water Main Renewal Program

The Region's overall infrastructure is aging, requiring more investment in preventive and planned maintenance. In response, Peel has established a comprehensive asset management program which includes the water main assessment and renewal. The program is an ongoing plan of upgrading Peel's linear infrastructure to ensure long term integrity. The program involves repair of mains or replacement of existing mains to improve water flow, ensure good quality water and upsize if required to meet future planning needs; all to provide higher level service to our consumers.

The Region determines priority of water mains replacement based on the following factors:

- 1) Water main age
- 2) Water quality trend
- 3) Water main size and material type
- 4) Water main breaks and leak history
- 5) Future municipal and city projects and road re-construction
- 6) Cost of replacement

The majority of the water main replacement projects are undertaken in partnership with road and sewer renewal projects for improved cost effectiveness and minimized public inconvenience. Using these criteria, Peel plans the water main renewal program in a financially responsible manner.

In 2009, the Region's water main repair and replacement program involved the replacement of 41.3 km of water mains.

In 2009, the Federal and Provincial governments announced an Economic Action Plan that included an Infrastructure Stimulus Fund (ISF) to provide funding for construction-ready distribution projects. Approximately 57.4 km of watermain were approved for ISF funding. These watermain replacements will be completed by March 31, 2011.

The header features a blue background with a white and orange 'water quality report' title. The background includes a stylized wave pattern and bubbles rising from the left side.

water quality report

5.4 Community Lead Testing Program

Under the Ministry of the Environment mandate, all large municipal residential water system owners such as Peel must have a specific number of private residences and non-residential premises tested for lead. To be eligible to participate in Peel's program and have water tested for lead, homes and buildings must meet the following conditions:

- 1) homes or buildings built prior to 1960
- 2) plumbing connected or suspected to be connected to lead service pipes
- 3) lead plumbing or suspected of being made of lead

The Community Lead Testing is a voluntary program, which is conducted semi-annually, December 15 to April 15 and June 15 to October 15 of each year. Every sampling period, Peel staff recruits owners of homes and businesses that meet the program conditions, coordinates the collection of samples, and provides test results and assistance in the results interpretation. The Region advertised for volunteer sampling locations from both residents and businesses through local newspapers releases, mobile signs, regional events, direct consumer contact, and the website. Peel is pleased with the community response and participation to the program.

2009 testing revealed not detected or low level concentrations of lead. The majority of residential homes and businesses sampled and tested throughout the region met the Ontario's standard for lead levels in drinking water. Based on 2009 winter and summer test results and recent amendments to the lead testing requirements, Alton drinking water system has qualified for a reduced sampling regime.

In addition to the provincially mandated water testing for lead, cast iron water mains with lead joints have become a priority for replacement to help minimize potential sources of lead in Peel's drinking water. This initiative is carried out under the asset management and linear infrastructure renewal program.

water quality report

5.5 Water Main Flushing Program

The goals of the water main flushing program are to maintain adequate chlorine residual in the system. Water main flushing is also conducted in response to a customer complaint. Flushing frequency is greater in areas where the residual tends to be low in comparison to a target residual. 251 m³ of water were flushed during 2009.

5.6 Water Main Swabbing Program

The objective of the water main swabbing program is removal of water main mineral and residue build up to improve water quality and restore distribution system capacity. Swabbing involves inserting a swab (most commonly used is polyurethane foam) into the main through a hydrant and pushing it along the water main by water pressure.

As the swab passes through the pipe, it scours the sediment and residue attached to the water main, which is later flushed from the system through the hydrant. Peel staff diligently assesses the condition of water mains and continuously monitors quality of water supply. Swabbing program activities are coordinated on basis and frequency dictated by the monitoring programs and conducted in coordination with the community residents.



5.7 Hydrant Inspection Program

The Region of Peel has in place a hydrant inspection program designed to verify the functionality of each fire hydrant. During an inspection, the hydrant branch is flushed out and the valves are checked. Any hydrants identified as non-functional are repaired immediately. 62 hydrants were repaired in Alton drinking water system during 2009.

water quality report

5.8 Drinking Water Sampling Station Program

The Region installed 26 drinking water sampling stations throughout Caledon to improve drinking water quality assessment and monitoring methods and to improve customer service. Sampling stations are located at carefully selected points within the distribution system in Alton, Caledon Village, Caledon East, Mono Mills, Inglewood, Palgrave, Cheltenham and Terra Cotta to ensure the water samples collected accurately represent the drinking water supplied to the consumers. The installation of stations has decreased the need to enter homes and businesses to obtain water samples and allow Peel to meet its commitments to water quality with the least amount of impact to customers.



5.9 Private Well Abandonment Program

The Region of Peel's Private Well Abandonment Program decommissions old, unused private wells in Caledon, in accordance with Ontario Regulation 903. The Program intends to gradually eliminate potential pathways of groundwater contamination in areas where groundwater is the source for municipal drinking water. The Program is carried out on a first come, first serve basis, with each well decommissioning request being evaluated prior to the commencement of any decommissioning work.

water quality report

Appendix A

Summary of Water Quality Parameters

Terms you need to know

Term	Definition
MAC	Maximum Acceptable Concentration
IMAC	Interim Maximum Acceptable Concentration
Aesthetic Objectives(AO)	AO are established for substances that affect the taste, smell and color of water or interfere with water quality control practices. These substances do not affect health.
(HR) Health Related Parameter	Health related parameters are a concern for acute or and/or chronic exposure
(OG) Operational Guidelines	OG are established for substances that need to be controlled to ensure the efficient treatment and distribution of water.
AOC	The assimilable organic carbon (AOC) test is a standardized measure of the bacterial growth potential of treated water.
R2A test	R2A test includes use of sensitive medium for the determination of the heterotrophic total bacterial count in drinking water. R2A is especially suitable for the recovery of stressed and chlorine-tolerant bacteria from drinking water
NTU	Nephelometric Turbidity Unit
ND	Not Detected
TCU	True Colour Units
cfu/100 ml	Colony Forming Units/100 millilitre
$\mu\text{S/cm}$	micro Siemens per centimetre
L	Liter
$\mu\text{g/L}$	Micrograms per liter. This is a measure of concentration of a parameter in water, also called parts per billion (ppb)
mg/L	Milligrams per liter. This is a measure of concentration of a parameter in water, also called parts per million (ppm)



water quality report

Parameters Information (E.coli/TC/HPC/AOC/R2A)

➤ **Escherichia coli (EC)**

Escherichia coli is a fecal coliform and can be detected using approved lab methods. Escherichia coli is present in fecal matter and prevalent in sewage, but is rapidly destroyed by chlorine. It is a strong indicator of recent fecal pollution. Presence of Ecoli bacteria in a sample of drinking water signifies potentially inadequate treatment. Corrective action needs to be taken and confirmatory samples collected

➤ **Total Coliform (TC)**

Total Coliform bacteria are part of a family of bacteria called, Enterics. Coliform bacteria grow under the same conditions as disease causing bacteria. That allows us to use them as *indicator organisms*. Presence of coliform bacteria in a sample of drinking water signifies inadequate treatment and is unacceptable. Corrective action needs to be taken and confirmatory samples collected..

➤ **Heterotrophic Plate Count**

Heterotrophic plate count (HPC) results give an indication of overall water quality in drinking-water systems. HPC results are used as a tool for monitoring the overall quality of the water, both in post-treatment and in the distribution system. A HPC result is not an indicator of water safety but is used as an indicator of water integrity within the water system.

➤ **Assimilable Organic Carbon (AOC)**

Growth of bacteria in drinking water distribution and storage systems can lead to the deterioration of water quality, non-compliance with water quality standards, and increased operating costs. Growth or re-growth results from viable bacteria surviving the disinfection process and utilizing nutrients in the water and biofilm to sustain growth. Factors other than nutrients that influence regrowth include



water quality report

AOC. Not all organic compounds are equally susceptible to microbial decomposition; the fraction of dissolved organic carbon (DOC) that provides energy and carbon for bacterial growth is assimilable organic carbon (AOC). The Region of Peel monitors the levels of AOC as an extra precautionary measure to ensure the water quality remains at its highest standard. Assimilable organic carbon is not a regulatory requirement.

➤ **R2A Media Testing**

It is a testing method used to obtain bacterial plate counts from treated potable water. R2A is very low in nutrients and when combined with low incubation temperature and long incubation period, it stimulates the growth of stressed and chlorine-tolerant bacteria. The Region of Peel monitors the levels of R2A media results as an extra precautionary measure to ensure the water quality remains at its highest standard.

➤ **Disinfection By-products**

Disinfection of drinking-water is essential to protect the public from waterborne infectious and parasitic diseases. Disinfection inactivates bacteria in the water and protects the water pipes from any subsequent contamination during storage or distribution. The most commonly used disinfectant is chlorine. The use of chlorine may lead to the formation of by-products, including trihalomethanes (THMs). THMs are formed when compounds left in the water after treatment combine with the chlorine.

water quality report

Alton's Permit to Take Water testing requirements

Date of Legal Instrument Issued	Parameter	Alton Well 3 Result (Max – Min)	Alton Well 4 Result (Max – Min)	Unit of Measure
PTTW (8/11/05)	Chloride	172-180	41-119	mg/l
	Conductivity @ 25C	1200-1210	609-947	µS/cm
	Nitrate (NO3) as N	5.0-5.0	0.7-3.2	mg/l
	Nitrite (NO2) as N	ND	ND	mg/l
	Phenolic Compounds	ND	ND	mg/l
	A EXT- 2,3,6-Trichlorophenol	ND	ND	µg/l
	A EXT- 2-Nitrophenol	ND	ND	µg/l
	A EXT- 3,4,5-Trichlorophenol	ND	ND	µg/l
	A EXT- Pentachlorophenol	ND	ND	µg/l
	BNA EXT- 1-Chloronaphthalene	ND	ND	µg/l
	BNA EXT- 1-Methylnaphthalene	ND	ND	µg/l
	BNA EXT- 2,3,4,5-Tetrachlorophenol	ND	ND	µg/l
	BNA EXT- 2,3,4,6-Tetrachlorophenol	ND	ND	µg/l
	BNA EXT- 2,3,4-Trichlorophenol	ND	ND	µg/l
	BNA EXT- 2,3,5,6-Tetrachlorophenol	ND	ND	µg/l
	BNA EXT- 2,3,5-Trichlorophenol	ND	ND	µg/l
	BNA EXT- 2,4,5-Trichlorophenol	ND	ND	µg/l
	BNA EXT- 2,4,6-Trichlorophenol	ND	ND	µg/l
	BNA EXT- 2,4-Dichlorophenol	ND	ND	µg/l
	BNA EXT- 2,4-Dimethylphenol	ND	ND	µg/l
	BNA EXT- 2,4-Dinitrophenol	ND	ND	µg/l
	BNA EXT- 2,4-Dinitrotoluene	ND	ND	µg/l
	BNA EXT- 2,6-Dichlorophenol	ND	ND	µg/l
	BNA EXT- 2,6-Dinitrotoluene	ND	ND	µg/l
	BNA EXT- 2-Chloronaphthalene	ND	ND	µg/l
	BNA EXT- 2-Chlorophenol	ND	ND	µg/l
	BNA EXT- 2-Methylnaphthalene	ND	ND	µg/l

water quality report

Date of legal Instrument Issued	Parameter	Alton Well 3 Result (Max – Min)	Alton Well 4 Result (Max – Min)	Unit of Measure
	BNA EXT- 4,6-Dinitro-o-cresol	ND	ND	µg/l
	BNA EXT- 4-Bromophenyl phenyl ether	ND	ND	µg/l
	BNA EXT- 4-Chloro-3-methylphenol	ND	ND	µg/l
	BNA EXT- 4-Chlorophenyl phenyl ether	ND	ND	µg/l
	BNA EXT- 4-Nitrophenol	ND	ND	µg/l
	BNA EXT- 5-nitro Acenaphthene	ND	ND	µg/l
	BNA EXT- Acenaphthene	ND	ND	µg/l
	BNA EXT- Acenaphthylene	ND	ND	µg/l
	BNA EXT- Anthracene	ND	ND	µg/l
	BNA EXT- Benz(a)anthracene	ND	ND	µg/l
	BNA EXT- Benzo(a)pyrene	ND	ND	µg/l
	BNA EXT- Benzo(b)fluoranthene	ND	ND	µg/l
	BNA EXT- Benzo(g,h,i)perylene	ND	ND	µg/l
	BNA EXT- Benzo(k)fluoranthene	ND	ND	µg/l
	BNA EXT- Benzylbutylphthalate	ND	ND	µg/l
	BNA EXT- Biphenyl	ND	ND	µg/l
	BNA EXT- Bis(2-chloroethoxy)methane	ND	ND	µg/l
	BNA EXT- Bis(2-chloroethyl)ether	ND	ND	µg/l
	BNA EXT- Bis(2-Chloroisopropyl)ether	ND	ND	µg/l
	BNA EXT- Bis(2-ethylhexyl)phthalate	ND	ND	µg/l
	BNA EXT- Camphene	ND	ND	µg/l
	BNA EXT- Chrysene	ND	ND	µg/l
	BNA EXT- Dibenz(a,h)anthracene	ND	ND	µg/l
	BNA EXT- Di-n-butylphthalate	ND	ND	µg/l
	BNA EXT- Di-n-octylphthalate	ND	ND	µg/l
	BNA EXT- Diphenylether	ND	ND	µg/l
	BNA EXT- Fluoranthene	ND	ND	µg/l
	BNA EXT- Fluorene	ND	ND	µg/l

water quality report

Date of Legal Instrument Issued	Parameter	Alton Well 3 Result (Max – Min)	Alton Well 4 Result (Max – Min)	Unit of Measure
	BNA EXT- Indeno (1,2,3-cd) pyrene	ND	ND	µg/l
	BNA EXT- Indole	ND	ND	µg/l
	BNA EXT- m,p-Cresol	ND	ND	µg/l
	BNA EXT- Naphthalene	ND	ND	µg/l
	BNA EXT- N-Nitrosodi-n-propylamine	ND	ND	µg/l
	BNA EXT- N-Nitrosodiphenylamine/diphenylamine	ND	ND	µg/l
	BNA EXT- o-Cresol	ND	ND	µg/l
	BNA EXT- Perylene	ND	ND	µg/l
	BNA EXT- Phenanthrene	ND	ND	µg/l
	BNA EXT- Phenol	ND	ND	µg/l
	BNA EXT- Pyrene	ND	ND	µg/l
	VOCs-1,1,1-Trichloroethane	ND	ND	µg/l
	VOCs-1,1,2,2-Tetrachloroethane	ND	ND	µg/l
	VOCs-1,1,2-Trichloroethane	ND	ND	µg/l
	VOCs-1,1-Dichloroethane	ND	ND	µg/l
	VOCs-1,1-Dichloroethene	ND	ND	µg/l
	VOCs-1,2-Dichlorobenzene	ND	ND	µg/l
	VOCs-1,2-Dichloroethane	ND	ND	µg/l
	VOCs-1,2-Dichloropropane	ND	ND	µg/l
	VOCs-1,3-Dichlorobenzene	ND	ND	µg/l
	VOCs-1,4-Dichlorobenzene	ND	ND	µg/l
	VOCs-2-Chloroethyl Vinyl Ether	ND	ND	µg/l
	VOCs-Benzene	ND	ND	µg/l
	VOCs-Bromodichloromethane	ND	ND	µg/l
	VOCs – Bromoform	ND	ND	µg/l
	VOCs-Bromomethane	ND	ND	µg/l
	VOCs-Carbon Tetrachloride	ND	ND	µg/l
	VOCs-Chlorobenzene	ND	ND	µg/l

water quality report

Date of Legal Instrument Issued	Parameter	Alton Well 3 Result (Max – Min)	Alton Well 4 Result (Max – Min)	Unit of Measure
	VOCs-Chloroethane	ND	ND	µg/l
	VOCs-Chloroform	ND	ND	µg/l
	VOCs-Chloromethane	ND	ND	µg/l
	VOCs-cis (Z)1,2-Dichloroethene	ND	ND	µg/l
	VOCs-cis-1,3-Dichloropropene	ND	ND	µg/l
	VOCs-Dibromochloromethane	ND	ND	µg/l
	VOCs-Ethyl Benzene	ND	ND	µg/l
	VOCs-m/p-Xylene	ND	ND	µg/l
	VOCs-Methylene Chloride	ND	ND	µg/l
	VOCs-MTBE	ND	ND	µg/l
	VOCs-o-Xylene	ND	ND	µg/l
	VOCs-Styrene	ND	ND	µg/l
	VOCs-Tetrachloroethene	ND	ND	µg/l
	VOCs-Toluene	ND	ND	µg/l
	VOCs-trans-1,2-Dichloroethene	ND	ND	µg/l
	VOCs-trans-1,3-Dichloropropene	ND	ND	µg/l
	VOCs-Trichloroethene	ND	ND	µg/l
	VOCs-Trichlorofluoromethane	ND	ND	µg/l
	VOCs-Vinyl Chloride	ND	ND	µg/l
	METALS – Thallium, Tl	ND	ND	mg/l
	METALS-Aluminum, Al	0.136-0.220	0.115-0.174	mg/l
	METALS-Antimony, Sb	ND	ND	µg/l
	METALS-Arsenic, As	ND	ND	µg/l
	METALS-Barium, Ba	0.170-0.176	0.112-0.152	mg/l
	METALS-Beryllium, Be	ND	ND	mg/l
	METALS-Boron, B	0.043-0.047	0.033-0.043	mg/l
	METALS-Cadmium, Cd	ND	ND	mg/l
	METALS-Calcium, Ca	103-106	68.3-96.0	mg/l

water quality report

Date of Legal Instrument Issued	Parameter	Alton Well 3 Result (Max – Min)	Alton Well 4 Result (Max – Min)	Unit of Measure
	METALS-Chromium, Cr	ND	ND	mg/l
	METALS-Cobalt, Co	ND	ND	mg/l
	METALS-Copper, Cu	ND	ND	mg/l
	METALS-Iron, Fe	ND	0.013-0.019	mg/l
	METALS-Lead, Pb	ND	ND	µg/l
	METALS-Magnesium, Mg	27.7-27.9	21.4-25.7	mg/l
	METALS-Manganese, Mn	0.002-0.007	0.002-0.003	mg/l
	METALS-Mercury, Hg	ND	ND	mg/l
	METALS-Potassium, K	2.68-2.88	1.43-2.15	mg/l
	METALS-Selenium, Se	ND	ND	mg/l
	METALS-Silicon, Si	4.99-5.37	5.12-5.62	mg/l
	METALS-Silver, Ag	ND	ND	mg/l
	METALS-Sodium, Na	89.0-105	14.6-60.6	mg/l
	METALS-Strontium, Sr	0.244-0.248	0.221-0.252	mg/l
	METALS-Titanium, Ti	ND	ND	mg/l
	METALS-Uranium, U	0.0006-0.0006	0.0004-0.0005	mg/l
	METALS-Zinc, Zn	ND	ND	mg/l

ND indicates Not detectable, < indicates below Method Detection Limit. (MDL).

water quality report

Summary of microbiological testing done for the reporting period of Jan 1 to Dec 31, 2009

	Number of Samples	Range of E. Coli Or Fecal Results (cfu/100 ml) (Min -Max)	Range of Total Coliform Results (cfu/100 ml) (Min - Max)	Number of HPC Samples	Range of HPC Results (cfu/ml) (Min - Max)
Alton Well #1 Raw	52	0	0	52	0-13
Alton Well #2 Raw	52	0	0-82	52	0-23
Alton Well #3 Raw	52	0	0	52	0
Alton Well #3 Treated	52	0	0	52	0
Alton Well #4 Raw	52	0	0	52	0
Alton Well #4 Treated	52	0	0	52	0-1
Distribution	208	0	0	208	0

Summary of inorganic parameters tested for the reporting period of Jan 1 to Dec 31, 2009

Test Parameter (Schedule 23)	Units	Result (Min-Max)	MAC	Parameter Information
Antimony, Sb	µg/l	ND	6	Rarely detected in Ontario Drinking Water
Arsenic, As	µg/l	ND	25	Sometimes found in high concentration in ground water in hard rock areas through the natural dissolution of arsenic containing minerals
Barium, Ba	mg/l	0.144-0.165	1.0	Common in sedimentary rocks. Hard water contains small amounts of Barium
Boron, B	mg/l	0.042-0.046	5.0	Normally found in very small levels in drinking water
Cadmium, Cd	mg/l	ND	0.005	Rare element unlikely to be present as natural contaminant in drinking water
Chromium, Cr	mg/l	ND	0.05	Trivalent chromium naturally occurs and is not considered toxic
Mercury, Hg	mg/l	ND	0.001	Sources in drinking water can be air pollution, waste incineration and metal refining operations
Selenium, Se	mg/l	ND	0.01	Naturally occurs in water at trace levels
Uranium, U	mg/l	ND	0.02	Normally occurring in granite and other mineral deposits, leaches into water
Alkalinity, Total	mg/l (CaCO ₃)	269-305	30-500	Water resistance to effects of acids added to water
Ammonia + Ammonium, Colourimetric	mg/l	ND		Natural decay of organic material
Chloride	mg/l	42.2-209	250	Non-toxic material naturally present in drinking water

water quality report

CONDUCTIVITY @ 25°C	µS/cm	945-1170		Related to inorganics dissolved in water
Fluoride (F)-IC	mg/l	ND	1.5	Added to water in optimum level for control of tooth decay
Nitrate (NO3)	mg/l as N	0.721-5.58	10.0	Present in ground water as a result of plant or animal material decay, fertilizers, sewage or treated wastewater
Nitrite (NO2)	mg/l as N	ND	1.0	Usually present in ground water, and is oxidized to nitrate when chlorinated
pH		7.8-7.9		Indicates water acidity
Sulphate(SO4)	mg/l	37.6-38.3	500	Naturally occurring
TKN I, Colourimetric	mg/l	ND		Natural decay of organic material
Total Dissolved Solids	mg/l	522-662	500	Refers mainly to inorganic substances dissolved in water
Calcium, Ca	mg/l	91.9-108		Naturally occurring
Iron, Fe	mg/l	ND-0.034		In ground water as a result of mineral deposits and chemically reducing underground conditions
Lead, Pb	µg/l	ND-0.620	10	It is only present as a result of corrosion of lead solder, lead containing brass fittings or lead pipes
Manganese, Mn	mg/l	ND-0.022	0.05	In ground water because of chemically reducing underground conditions coupled with presence of manganese mineral deposits
Sodium, Na	mg/l	55.0-100	20	Naturally occurring or from water softening process
Zinc, Zn	mg/l	ND	5	Caused by corrosion taking place in galvanized pipes
Total Hardness by Calculation	mg/l	337-389	80-100	Naturally occurring

Summary of organic parameters tested during the reporting period of Jan 1 to Dec 31, 2009

Test Parameter (Schedule 24)	Units	Results (Min-Max)	MAC	Parameter Information
Alachlor	µg/l	ND	5	Herbicide for weeds control banned in 1985
Aldicarb	µg/l	ND	9	Insecticide used in low quantities for control of specified insects. Banned in 1980s
Aldrin + Dieldrin	µg/l	ND	0.7	Pesticides for insect control banned in 1969
Atrazine + N-dealkylated metabolites	µg/l	ND	5	Herbicide on corn for annual grass control. It is highly persistent and moderately mobile in soil
Azinphos-methyl	µg/l	ND	20	Insecticide against foliage-feeding insects
Bendiocarb	µg/l	ND	40	Insecticide used in buildings and greenhouses
Benzene	µg/l	ND	5	Present in gasoline and other refined petroleum products
Benzo(a)pyrene	µg/l	ND	0.01	Formed during the incomplete burning of organic matter and poorly adjusted diesel exhaust

water quality report

Bromoxynil	µg/l	ND	5	Herbicide for control of specific weeds
Carbaryl	µg/l	ND	90	Insecticide used in agriculture and forestry
Carbofuran	µg/l	ND	90	Insecticide used in agriculture
Carbon Tetrachloride	µg/l	ND	5	Only found in ground water from old chlorinated solvent industry sites
Chlordane (Total)	µg/l	ND	7	Insecticide once used in agriculture, banned in 1994
Chlorpyrifos	µg/l	ND	90	Common insecticide for insect control
Cyanazine	µg/l	ND	10	Herbicide for control of weeds in crop and non-crop areas
Diazinon	µg/l	ND	20	Insecticide for dwelling pests, flies, ants and cockroaches.
Dicamba	µg/l	ND	120	Herbicide for weed in grains
1,2-Dichlorobenzene	µg/l	ND	200	Used in chemical blends
1,4-Dichlorobenzene	µg/l	ND	5	Was widely used in toilet pucks and mothballs, banned in 1988
Dichlorodiphenyltrichloroethane (DDT) + metabolites	mg/l	ND	0.03	DDT use was banned in Ontario in 1988
1,2-Dichloroethane	µg/l	ND	5	Used as a solvent and fumigant
1,1-Dichloroethylene (vinylidene chloride)	mg/l	ND	0.014	Used in the food packaging industry and the textile industry for furniture and automotive upholstery
Dichloromethane	µg/l	ND	50	Industrial solvent for paint and degreasing agent
2,4-Dichlorophenol	µg/l	ND	900	Present in drinking water only as a result of industrial contamination
2,4-Dichlorophenoxy acetic acid (2,4-D)	µg/l	ND	100	Herbicide for cereal crop and lawn weed control
Diclofop-methyl	µg/l	ND	9	Herbicide grass control in grains and vegetables
Dimethoate	µg/l	ND	20	Miticide and insecticide
Dinoseb	µg/l	ND	10	Contact herbicide and desiccant. It is no longer used in Ontario
Diquat	ppb	ND	70	Herbicide used as a crop desiccant in seed crops
Diuron	µg/l	ND	150	Herbicide for control of vegetation in crop and non-crop areas
Glyphosate	µg/l	ND	280	Herbicide for weed control
Heptachlor + Heptachlor Epoxide	µg/l	ND	3	Insecticide once used in agriculture, banned in 1969
Lindane (Total)	µg/l	ND	4	Insecticide used for seed treatment
Malathion	µg/l	ND	190	Insecticide used in fruits and vegetables
Methoxychlor	µg/l	ND	900	Insecticide
Metolachlor	µg/l	ND	50	Selective herbicide for pre-emergence and pre-plant broad leaf weed control
Metribuzin	µg/l	ND	80	Herbicide for control of weed and grasses

water quality report

Monochlorobenzene	µg/l	ND	80	Industrial solvent
Paraquat	ppb	ND	10	Highly toxic herbicide used for desiccation of seed crops
Parathion	µg/l	ND	50	Insecticide for foliar pests and adult stage of root maggots
Pentachlorophenol	µg/l	ND	60	It is rarely found today but was extensively used as a pesticide and wood preservative
Phorate	µg/l	ND	2	Insecticide for sucking insects and larvae's
Picloram	µg/l	ND	190	Herbicide for broad leaf weed and brush control on roads
Polychlorinated Biphenyls(PCB)	µg/l	ND	3	Primarily produced by the reaction of chlorine and natural organics
Prometryne	µg/l	ND	1	Herbicide used on select grass and weeds
Simazine	µg/l	ND	10	Herbicide for pre-emergence weed control
Total, Trihalomethanes	µg/l	12.0	100	Primarily produced by the reaction of chlorine and natural organics
Temephos	µg/l	ND	280	Insecticide for mosquito and black fly larvae control
Terbufos	µg/l	ND	1	Insecticide
Tetrachloroethylene	µg/l	ND	30	Industrial solvent
2,3,4,6-Tetrachlorophenol	µg/l	ND	100	Was normally used to preserve wood
Triallate	µg/l	ND	230	Herbicide for wilds oat control in crops
Trichloroethylene	µg/l	ND	50	Industrial solvent
2,4,6-Trichlorophenol	µg/l	ND	5	Pesticide
2,4,5-Trichlorophenoxy acetic acid (2,4,5-T)	µg/l	ND	280	Herbicide
Trifluralin	µg/l	ND	45	Herbicide for summer weed control
Vinyl Chloride	µg/l	ND	2	Synthetic chemical used in making PVC

* THMs: Latest annual average, measurement from distribution system sample.



water quality report

Operational testing done for the period of Jan 1 to Dec 31, 2009

	Number of Grab Samples	Range of Results (Min-Max)	Units
Turbidity	8760*	0.08-0.39	NTU
Chlorine	8760*	1.01 - 1.83	mg/L

* 8760 -number of samples based on continuous monitoring

water quality report

Appendix B

Water Quality At Home Tips

Water Quality Concern	Possible Cause	Suggested Solutions
Chlorine Odour and Taste	<ul style="list-style-type: none"> Chlorine getting combined with organics Chlorination of new water mains Effects of new plumbing Change of residency as chlorine concentration varies from location to location 	<p>Chlorine is necessary to control disease-causing organisms.</p> <p>To minimise the chlorine taste and smell in water;</p> <ul style="list-style-type: none"> Fill a pitcher and let it stand in the refrigerator overnight Blend the water for 5 minutes or pour between containers about 10 times Boil the water, let it cool down and then refrigerate Home plumbing may be flushed for a minute before water use (especially in the mornings, after water stands in the lines overnight)
Musty/Earthy /Sour/Grassy/ Foul Odour	<ul style="list-style-type: none"> Algae that bloom in the lake in the summer produces a metabolite called 'geosmin', which causes musty/earthy odour Dead-end water mains or areas with low water demand Poorly maintained hot water tanks Faucet Aerators/Screens and sink drains 	<ul style="list-style-type: none"> The algae are harmless and although the water may not be aesthetically pleasing, it is safe. Clean faucet aerators and screens on frequent basis Hot water tanks should be flushed periodically (every 2 to 3 years) to remove rust and scale Refrain from flushing solids/organics down the drain; stagnant wastewater in the drain may generate foul odours and potentially plug the drain
Milky/Cloudy Water	<ul style="list-style-type: none"> Air trapped in water due to water main breaks, water temperature or pressure change, plumbing work, construction work in the area, water shut-offs Hot water tank temperature may be set for too high 	<ul style="list-style-type: none"> Run all cold water taps at once for a couple of minutes to flush the lines and release the air Lower the hot water tank temperature if above 140F (60°C)
Blue/Green Stains on Fixtures	<ul style="list-style-type: none"> Copper in water due to copper plumbing 	<ul style="list-style-type: none"> Run water for 30 seconds to reduce the effects of local plumbing (metal concentration) prior to water consumption Keep fixtures dry and drip-free
Brown/Dirty Discoloured Water	<p>Change in water flow due to:</p> <ul style="list-style-type: none"> Water main break Hydrant use Local Fire Dead ends 	<ul style="list-style-type: none"> Open cold water faucets and flush water for 5 to 10 minutes, until clear Refrain from doing laundry to prevent clothes staining Hot water tank should be flushed periodically

water quality report

	<ul style="list-style-type: none"> Poorly maintained hot water tanks or Originated in hot water tank No water use for a longer period of time; return from vacation 	(every 2 to 3 years) <ul style="list-style-type: none"> Run cold and hot water separately to verify the cause; if hot water is the cause-tank needs a flush Open several faucets and flush the water standing in pipes that may have dissolved pipe scale material
White Flakes/Particles	<ul style="list-style-type: none"> Flakes are scale caused by hardness Faulty or disintegrating hot water tank tubing or lining 	<ul style="list-style-type: none"> Can be reduced by frequent cleaning of faucet aerators/screens and/or frequent flushing of hot water tanks Contact the hot water tank company
Pink Staining on Fixtures	<ul style="list-style-type: none"> Pink pigmented bacteria called <i>Serratia marcescens</i> Airborne bacteria not known to cause disease 	<ul style="list-style-type: none"> Scrub surfaces with a brush Disinfect with a strong bleach solution Allow disinfectant to penetrate for 10-20 minutes Rinse

What are my water characteristics?

Alton Water Parameters 2009	MAC/IMAC	Type of Objective	Results	Unit	Comments
Alkalinity (as CaCO ₃)	30 - 500	OG	269-305	mg/L (CaCO ₃)	Measure of resistance of the water to the effects of acids added to water (change in pH)
Conductivity	--	--	945-1170	µS/cm	Related to inorganics dissolved in water
pH	6.5-8.5	OG	7.8-7.9	No Units	Indicates acidity of water
Hardness (as CaCO ₃)	80 - 100	OG	337-389 19.69-22.72	mg/L (CaCO ₃) grains/Gallon	Naturally occurring
Total Dissolved Solids	500	AO	522-662	mg/L	Natural inorganics dissolved in water
Sodium *	200	AO	55.0-100	mg/L	Naturally occurring or water softening. Softening using a domestic water softener increases the sodium level in drinking water
Chloride	250	AO	42.2-209	mg/L	Naturally occurring, may produce salty taste at higher levels
Iron	0.30	AO	ND-0.034	mg/L	Naturally occurring
Manganese	0.05	AO	ND-0.022	mg/L	Naturally occurring
Fluoride	1.5	MAC	ND	mg/L	Naturally occurring or added to prevent tooth decay
Temperature	--	AO	8.4-12.7	°C	Naturally occurring

* The Medical Officer of Health is notified when Sodium concentration exceeds 20 mg/L



water quality report

Frequently Asked Questions and Answers on Water Quality

➤ **Is our water safe to drink?**

To protect public health, the Ministry of the Environment has established the Ontario Drinking Water Quality Standards (ODWS). These objectives help ensure that water used by the public is free from disease-causing organisms, hazardous amounts of toxic chemicals and radioactive materials. The Region of Peel is proud to report that it has met these standards in 2009.

➤ **Why do we use chlorine?**

Chlorine is used to kill bacteria, viruses and other organisms that can cause illness. We are regulated on the amount we can add to the water as per the standards in Ontario Regulation 170/03. The standard states that we must maintain chlorine residual at a minimum level of 0.05mg/L and cannot exceed a maximum level of 4 mg/L.

➤ **Is the water in Alton hard?**

Hardness is typically dissolved calcium and magnesium in the water measured as calcium carbonate. Upon heating, hard water has a tendency to form scale deposits and can form excessive scum with regular soaps. Conversely, soft water may result in accelerated corrosion of water pipes. Although Alton water is considered hard it is still acceptable for domestic purposes.

➤ **Should I buy a water softener?**

The purchase of a water softener is based mostly on personal preferences. Soapsuds are formed easier with soft water, therefore less detergent is used. The use of a water softener also reduces the formation of hardness scale in pipes and hot water tanks. Some consumers do not like the feel of soft water. For example, after rinsing you may still feel a soap film on your skin if you used soft water.

➤ **Why does the water sometimes look “cloudy” or “milky”?**

Tiny bubbles of air in the water cause the cloudiness. Those bubbles may also cause the water to appear white or foamy, similar to the appearance of water in a rushing stream. This does not indicate



water quality report

any problem and clears when the water is left to sit for a few minutes. This is just an aesthetic not a health concern. If cloudy water does persist, please notify the Region of Peel so that the matter can be investigated.

➤ **Is fluoride added to my water?**

The Region of Peel does not add fluoride to the water in the Alton area. Any fluoride found in the water is naturally occurring.

➤ **Why is my kettle stained inside?**

The presence of calcium and manganese in the water will stain a kettle. When water is boiled, calcium and manganese precipitates out of water and deposits on the element and the inner sides of the kettle. This does not pose a health risk. Staining can be prevented by regular rinsing with vinegar or lemon juice.

➤ **Why does the water sometimes look “rusty” yellow or Tea like?**

Yellow water is a common occurrence. Excessive levels of iron in drinking water may impart a brownish colour, often seen on laundered clothes, plumbing fixtures, and the water itself. Running your tap for a few minutes can clear the colour. No health risks are associated with this discolouration. If you are experiencing problems and your neighbours are not, the hot water tank or the pipes in your home are likely causing the problem.

➤ **Does the Region knock on the door to test water or leave a bottle to fill?**

Some of our water programs require testing on private premises, such as a residential homes or businesses. This would only be done by the Region with prior arrangements with the owner or tenant of the premise. Based on the stringent provincial guidelines, drinking water samples must be collected and handled by qualified persons and analysed at an accredited laboratory; therefore, Peel staff would not leave a bottle at the door requesting a sample of water for testing, and will always carry the Region of Peel identification card.



water quality report

There are many responsible home water treatment businesses that offer products that live up to their claims. Unfortunately, some companies and salespersons resort to grabbing the public's attention and misinforming them about the safety of the municipal drinking water supplies in an effort to sell their products.

To ensure that you are informed about the water quality in Peel and less likely to become a target of the company trying to sell you costly and inappropriate water treatment equipment, or if you have questions or concerns, please contact our Water Quality Team at 905-791-7800 ext 4685 or via e-mail to www.WaterQualityInquiries@peelregion.ca.

➤ **Why is lead sometimes present in water?**

Lead is a metal that can dissolve in water. Traditionally, lead compounds were used in plumbing fittings and in solder to join pipes together in water distribution systems. If water stays in a piping system that contains lead for long periods of time, lead may dissolve into the water.

➤ **How does Lead affect my Health?**

For more information contact Peel Public Health at www.region.peel.on.ca

To view our **Lead in Water Pamphlet**, please click on [Additional facts about lead in drinking water](#)

water quality report

Report Accessibility

The 2009 Annual Reports can be viewed by the public on-line at:

<http://www.peelregion.ca/pw/water/quality/reports> or picked up at the Region of Peel Office at 10 Peel Centre Drive, 4th floor, Brampton.

Other Sources from which you can get more information about drinking water and related issues:

 <p>Region of Peel <i>Working for you</i></p> <p>For information on Water Quality</p> <p>Region of Peel 10 Peel Centre Dr. Brampton ON L6T 4B9 Phone: 905-791-7800 Ext. 4685 Web site: www.peelregion.ca E-mail: info@peelregion.ca</p>	 <p>Region of Peel <i>Working for you</i></p> <p>For information on Lead Testing of Drinking Water</p> <p>Region of Peel 10 Peel Centre Dr. Brampton ON L6T 4B9 Phone: 905-791-7800 Ext. 4409 Web site: www.peelregion.ca E-mail: info@peelregion.ca</p>
 <p>Region of Peel <i>Working for you</i></p> <p>Region of Peel Public Health 44 Peel Centre Dr. Brampton, ON L6T 4B5 Phone: 905-799-7700 Web site: www.peelregion.ca/health</p>	 <p>watersmartpeel Smarter Today – Water Tomorrow</p> <p>10 Peel Centre Dr. Brampton, ON L6T 4B9 Phone: 905-791-7800 Ext. 4455 Web Site: www.watersmartpeel.ca</p>
 <p>Ontario</p> <p>Ministry of the Environment Phone: 416-325-4000 Toll-Free: 1-800-565-4923 Web site: www.ene.gov.on.ca</p>	 <p>Canada</p> <p>Environment Canada Inquiry Centre Phone: 819-997-2800 Toll-Free: 1-800-668-6767 Web Site: www.ec.gc.ca</p>